

SONY®

DIGITAL VIDEOCASSETTE PLAYER

DVW-522/522P

CONTROL PANEL EXTENSION KIT

BKDW-510

CONTROL PANEL CASE

BKDW-511

Digital BETACAM

OPERATION MANUAL English

1st Edition (Revised 2)

Serial No. 10001 and Higher (DVW-522)

Serial No. 10001 and Higher (DVW-522P)

WARNING

To prevent fire or shock hazard, do not expose the unit to rain or moisture.

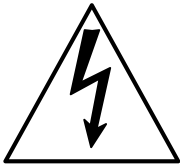
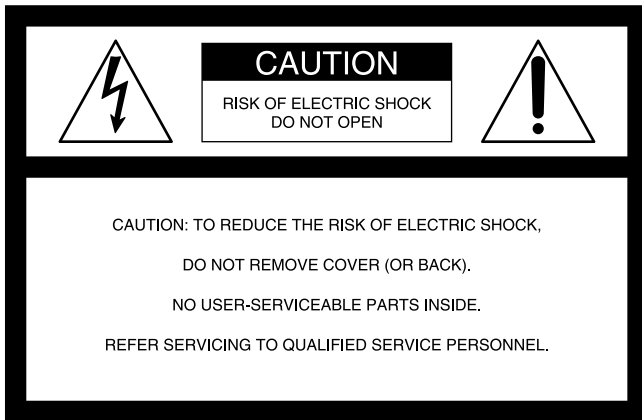

This symbol is intended to alert the user to the presence of uninsulated “dangerous voltage” within the product’s enclosure that may be of sufficient magnitude to constitute a risk of electric shock to persons.



This symbol is intended to alert the user to the presence of important operating and maintenance (servicing) instructions in the literature accompanying the appliance.

For the customers in the United Kingdom

**WARNING
THIS APPARATUS MUST BE EARTHED**

IMPORTANT

The wires in this mains lead are coloured in accordance with the following code:

- Green-and-yellow: Earth
- Blue: Neutral
- Brown: Live

As the colours of the wires in the mains lead of this apparatus may not correspond with the coloured markings identifying the terminals in your plug, proceed as follows:

The wire which is coloured green-and-yellow must be connected to the terminal in the plug which is marked by the letter E or by the safety earth symbol ϵ or coloured green or green-and-yellow.

The wire which is coloured blue must be connected to the terminal which is marked with the letter N or coloured black.

The wire which is coloured brown must be connected to the terminal which is marked with the letter L or coloured red.

For the customers in U.S.A. (DVW-522 only)

This equipment has been tested and found to comply with the limits for a Class A digital device, pursuant to Part 15 of the FCC Rules. These limits are designed to provide reasonable protection against harmful interference when the equipment is operated in a commercial environment. This equipment generates, uses, and can radiate radio frequency energy and, if not installed and used in accordance with the instruction manual, may cause harmful interference to radio communications. Operation of this equipment in a residential area is likely to cause harmful interference in which case the user will be required to correct the interference at his or her own expense.

You are cautioned that any changes or modifications not expressly approved in this manual could void your authority to operate this equipment.

The shielded interface cable recommended in this manual must be used with this equipment in order to comply with the limits for a digital device pursuant to Subpart B of Part 15 of FCC Rules.

WARNING: Using this unit at a voltage other than 120 V may require the use of a different line cord or attachment plug, or both. To reduce the risk of fire or electric shock, refer servicing to qualified service personnel.

For the customers in Europe (DVW-522P only)

This product with the CE marking complies with both the EMC Directive (89/336/EEC) and the Low Voltage Directive (73/23/EEC) issued by the Commission of the European Community.

Compliance with these directives implies conformity to the following European standards:

- EN60065: Product Safety
- EN55103-1: Electromagnetic Interference (Emission)
- EN55103-2: Electromagnetic Susceptibility (Immunity)

This product is intended for use in the following Electromagnetic Environment: E4 (controlled EMC environment, ex. TV studio).

Table of Contents

Chapter 1 Overview	1-1 Outline of the DVW-522/522P 1-1 1-2 Features 1-2 1-2-1 Digital BETACAM Format 1-2 1-2-2 Advanced Playback Functions 1-3 1-2-3 Ease of Operation 1-4 1-3 Optional Accessories 1-5
Chapter 2 Locations and Functions of Parts and Controls	2-1 Control Panel 2-1 2-1-1 Upper Control Panel 2-2 2-1-2 Lower Control Panel (Tape Transport Section) 2-3 2-1-3 Lower Control Panel (Search Operation Section) 2-4 2-1-4 Lower Control Panel (Time Code Section) 2-5 2-2 System Set-Up Panel 2-7 2-3 Connector Panel 2-9
Chapter 3 Setting Up the VTR	3-1 Connecting External Equipment 3-1 3-2 Set-Up Menu 3-2 3-2-1 Items That Require Setting for Operations 3-2 3-2-2 Changing Menu Settings 3-7 3-3 Superimposed Characters 3-14 3-4 Handling Cassettes 3-16 3-4-1 Recommended Cassettes 3-16 3-4-2 Inserting and Ejecting Cassettes 3-16
Chapter 4 Playback	4-1 Preparing for Playback 4-1 4-1-1 Setting Switches 4-1 4-1-2 Selecting Time Data to Be Displayed 4-2 4-2 Playback 4-3 4-2-1 Normal-Speed Playback 4-3 4-2-2 Variable-Speed Playback in Jog/Shuttle/Variable Modes 4-4 4-2-3 Capstan Override Playback 4-7
Chapter 5 Maintenance	5-1 Head Cleaning 5-1 5-2 Moisture Condensation 5-2
Appendixes	Specifications A-1
	Index I-1

1-1 Outline of the DVW-522/522P

The DVW-522/522P is a digital videocassette player designed exclusively for playback of tapes recorded in the Digital BETACAM format. It can be used for checking the contents of the recorded tapes, determining editing points, or playing demonstration tapes. As such, the functions required for tape editing are not provided on the DVW-522/522P.

The DVW-522 can be used in the NTSC color system while the DVW-522P can be used in the PAL color system, though they adopt component format.

1-2 Features

1-2-1 Digital BETACAM Format

The DVW-522/522P adopts the newly developed Digital BETACAM format as an extension of the BETACAM/BETACAM SP format. The Digital BETACAM format makes the best of the available recording area to achieve high-quality digital recording while keeping analog BETACAM tape playback compatibility. The following are developed for this purpose:

- Coefficient recording system
- Powerful error correction system
- High-quality precision heads and drum with dynamic tracking (DT) heads
- New automatic tracking system

These enable 120 minutes or more of playback time with Digital BETACAM (when using L-size cassettes), while the cassette size of the Digital BETACAM is exactly same as the normal BETACAM and BETACAM SP.

Note

The DVW-522/522P is designed exclusively for playing back digitally recorded video cassette tapes.

Tape format

The video and four-channel audio signals of each field are recorded onto the tape with six helical tracks, using a slightly slower tape speed and three times faster drum rotation speed than the conventional BETACAM and BETACAM SP formats.

The Digital BETACAM format has three longitudinal tracks: a CTL track, a time code (LTC) track and a cue audio track, identical to the conventional BETACAM and BETACAM SP format.

However, the conventional audio channel-1 track is deleted and used for expansion of the helical tracks. The larger drum diameter enables optimum digital recording, while analog BETACAM playback compatibility is maintained by specially developed time base corrector circuits.

1-2-2 Advanced Playback Functions

High-quality digital playback

The DVW-522/522P adopts a component digital video system and four-channel digital audio playback system which, along with an advanced error correction and concealment system, provide superb video and audio playback quality.

Note

The DVW-522/522P outputs only analog composite signals that have undergone digital-to-analog conversions.

Noiseless playback with DT heads

The DVW-522/522P's playback DT heads allow you to perform noiseless playback at any of 54 speeds, ranging from -1 to 3 times normal speed and including still-picture playback.

Built-in time code reader

Time codes and user's bits are read by a built-in time code reader during playback.

Computer servo system

Computer-controlled servo motors provide direct drive for the drum, capstan and two reels, enabling quick and accurate tape access.

Capstan override function

You can adjust the playback speed by $\pm 15\%$.

1-2 Features

1-2-3 Ease of Operation

Set-up menus

The initial settings of the VTR operation mode is easily done using the lower control panel.

Easy-to-use front panel

All important controls are located on the easy-to-use front panel, which can be angled as necessary. The front panel can also be completely detached for use as a remote control unit when used with the BKDW-510/511 Control Panel Extension Kit/Control Panel Case.

Digital hour meter

Three different kinds of hour displays and one cycle count display are supported; total elapsed time since the VTR was turned on, total drum revolution time, total tape running time and total number of threadings and unthreadings.

Self-diagnosis

When enabled through the maintenance menu, a self-diagnosis menu causes the VTR to analyze the cause of any malfunction which occurs, then display the relevant error code in the time counter display.

Easy-to-maintain plug-in boards

The VTR uses plug-in circuit boards to simplify servicing and inspection.

Mountability in standard 19-inch racks

The VTR can be mounted in an EIA-standard 19-inch rack. *For rack mounting, refer to the Maintenance Manual Part 1.*

1-3 Optional Accessories

The following accessories can be used with the VTR.

BKDW-510 Control Panel Extension Kit

Enables the control panel of the VTR to be detached and used as a remote control unit connected to the main unit with a supplied cable.

BKDW-511 Control Panel Case

Provides protection for a detached control panel being used in a control console.

References

- **Maintenance Manual Part 1**

Provides information necessary for users to install the VTR and its peripherals and to maintain the VTR and its optional equipment.

- **Maintenance Manual Part 2** (available on request)

Provides additional information to fully maintain the VTR. Contains details on adjustments that can be made, circuit diagrams, and so on.

2-1 Control Panel

The control panel consists of the following sections.

- Upper control panel
- Lower control panel: tape transport section, search operation section, time code section

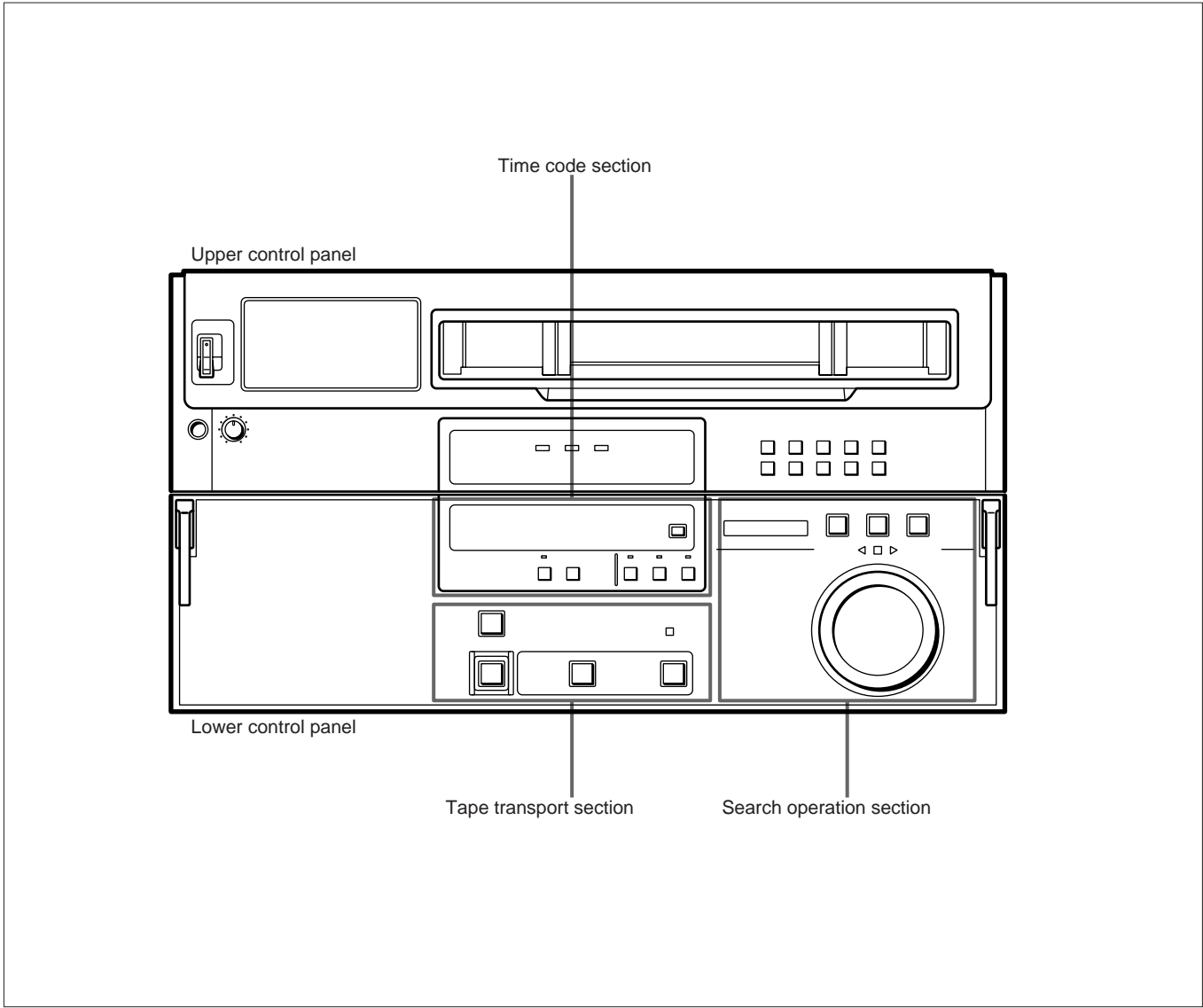

Control panel

2-1 Control Panel

2-1-1 Upper Control Panel

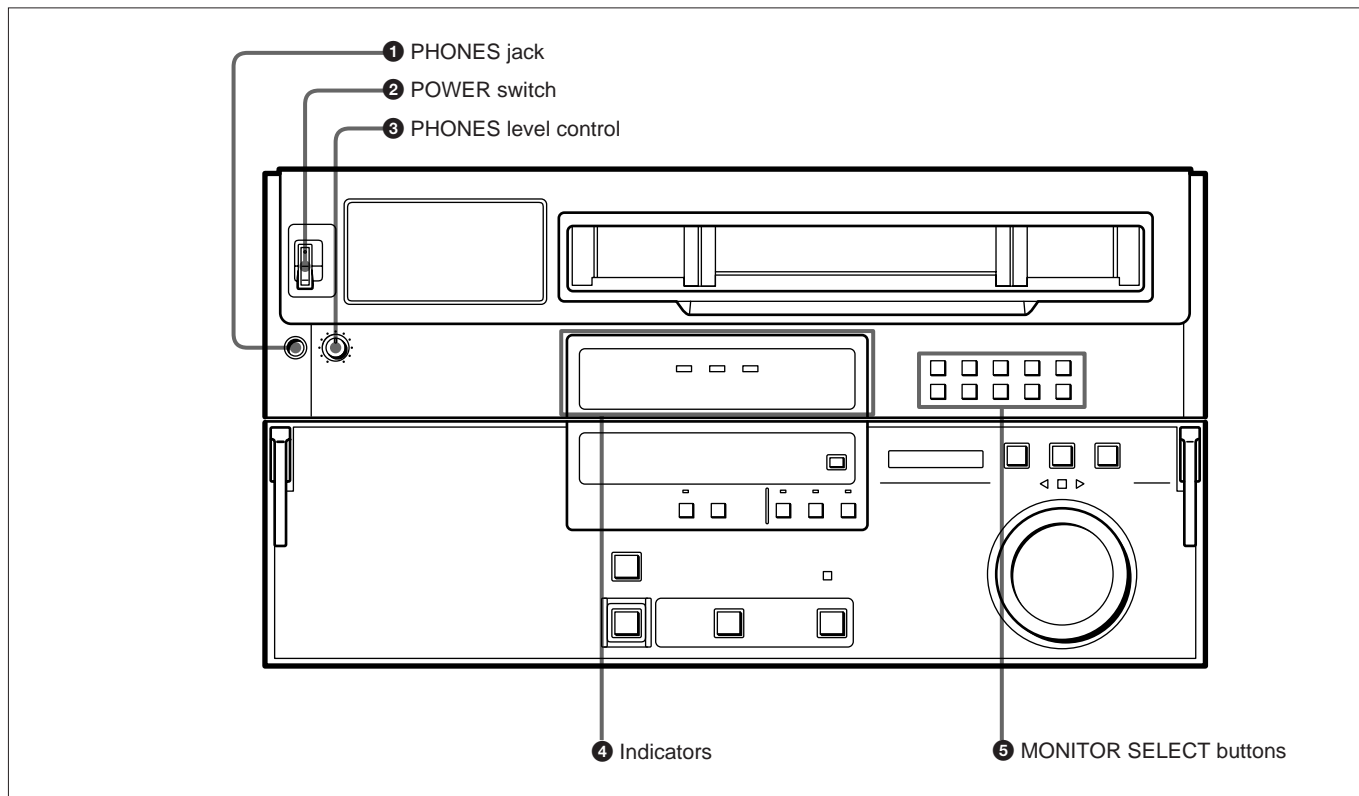

Upper control panel

1 PHONES jack

Connect 8 stereo headphones to monitor the audio during playback.

Adjust the volume level with the PHONES level control.

2 POWER switch

Set to ON to turn the VTR on. The audio level meters and time counter display light.

3 PHONES level control

Controls the level of the audio output from the PHONES jack. You can enable this control to simultaneously adjust the output level of the MONITOR OUTPUT connector on the connector panel.

For details, refer to the Maintenance Manual Part 1.

4 Indicators

Light or flash to show the status of the VTR.

VTR status indicators

Indicator	VTR status
CHANNEL CONDITION	Indicate the condition of the playback signal. Green indicator: indicates that the condition of the playback signal is good. Yellow indicator: indicates that the playback signal is somewhat deteriorated but is still reproducible. Red indicator: indicates that the playback signal is too poor for reproduction.
MENU 1/2/3	Indicate the menu bank selected by the SET UP SELECT switch on the system set-up panel.
LTC	Lights when the VTR is reading LTC signals on the playback tape.
VITC	Lights when the VTR is reading VITC signals on the playback tape.

5 MONITOR SELECT buttons

Press to select the signals output from the MONITOR OUTPUT L and R connectors.

You can mix the signals to be monitored by pressing two or more channel buttons (CH-1 to 4) for the same output channel (L or R).

Mixed signals from both the L and R output channels are output from the RF ADAPTOR connectors.

2-1-2 Lower Control Panel (Tape Transport Section)

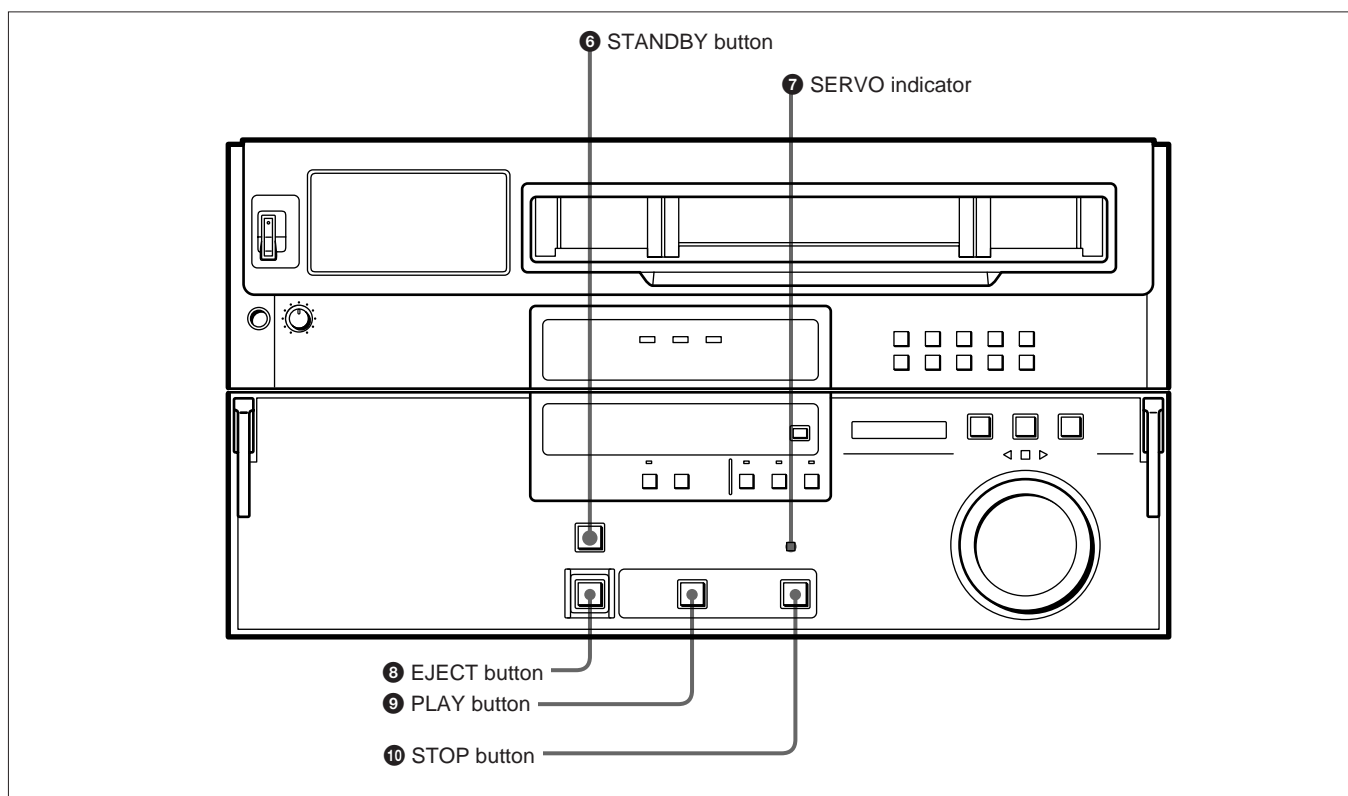

Lower control panel (tape transport section)

6 STANDBY button

Pressing this button in other than standby mode makes it light and places the VTR in standby mode. Since the head-drum rotates in standby mode, the tape can thus start sooner than in non-standby mode.

When you press this button while in standby mode the button extinguishes, the VTR exits standby mode, the tape tension is released, and the drum stops rotating. If more than eight minutes (factory preset time) elapse while the VTR is in standby mode, the VTR automatically exits standby mode to prevent tape and head clogging.

7 SERVO indicator

Lights when the drum servo and capstan servo lock.

8 EJECT button

Ejects the cassette. Resets the display when CTL codes appear in the time counter display.

9 PLAY button

Starts playback.

10 STOP button

Stops the tape (stop mode).

In stop mode, the tape is wound around the head-drum, but the head-drum continues to rotate. The VTR enters stop mode whenever you load a cassette.

2-1 Control Panel

2-1-3 Lower Control Panel (Search Operation Section)

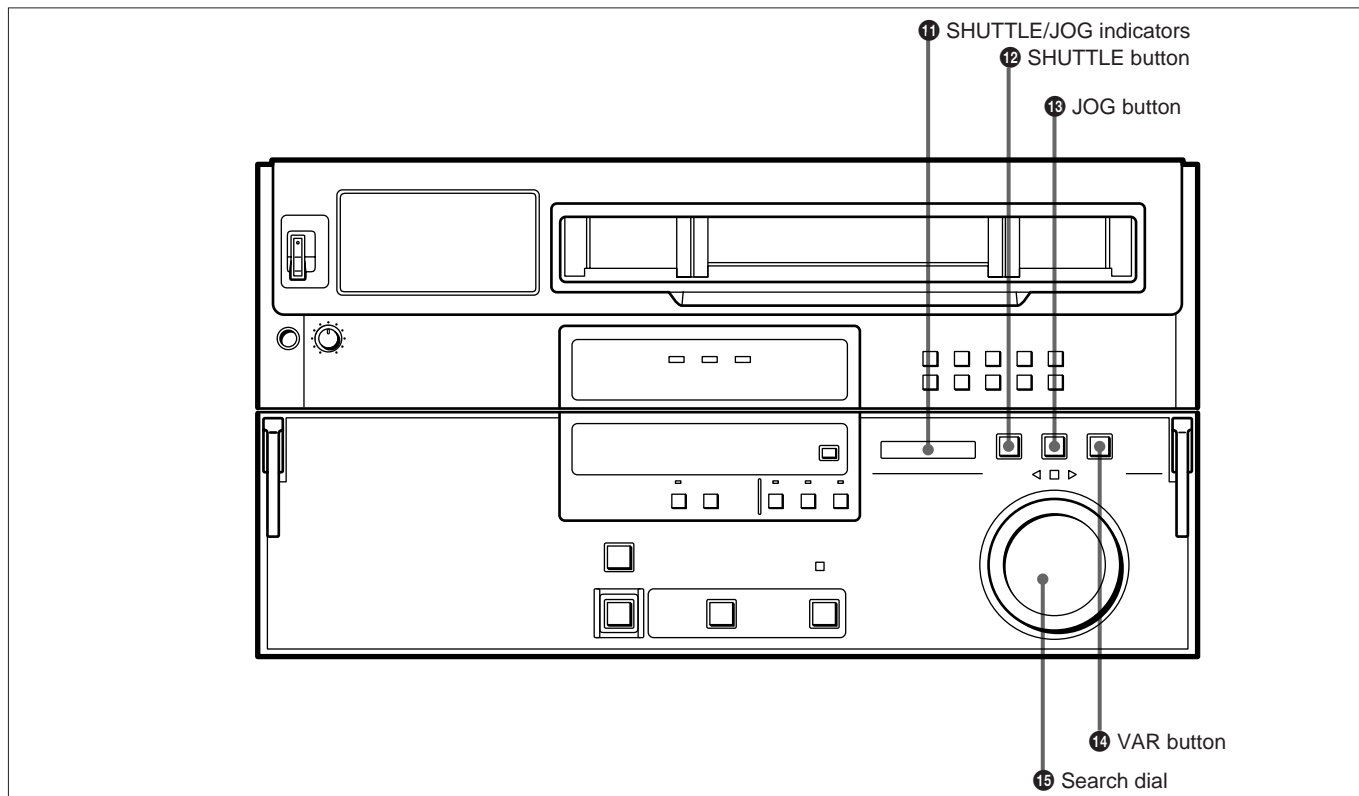

Lower control panel (search operation section)

11 SHUTTLE/JOG indicators

One of these indicators lights to show the current search mode.

12 SHUTTLE button

Press to select shuttle mode, which allows you to use the search dial to set playback the tape at 0 to ± 50 times normal speed when playing a Digital BETACAM tape. The SHUTTLE indicator lights. The search dial clicks at the positions corresponding to 0 (still picture) and ± 10 times normal speed.

13 JOG button

Press to select jog mode, which allows you to use the search dial to set playback the tape at 0 to ± 1 or ± 3 times normal speed (selectable with the set-up menu). The JOG indicator lights. The search dial does not click, the playback speed being proportional to the speed at which you rotate the dial.

14 VAR button

Selects variable speed playback with noiseless picture at any of 54 steps within a range of -1 to $+3$ times normal speed. The VAR indicator lights. The search dial clicks at the positions corresponding to still and normal playback speed.

15 Search dial

Rotate to search for edit points.

Rotate the dial clockwise for forward playback (the ► indicator lights) or counterclockwise for reverse playback (the ◀ indicator lights). While the VTR is in stop mode, the ■ indicator lights.

Pressing this dial toggles the VTR between shuttle and jog modes, with either the SHUTTLE or JOG indicator lighting to indicate the selected mode.

Shuttle mode: Playback speed corresponds to the angle of rotation of the dial (0 to about ± 50 times normal speed when playing back a Digital BETACAM tape).

Jog mode: The dial does not click. The playback speed corresponds to the rotational speed of the dial (0 to ± 1 or 0 to ± 3 times normal speed).

Variable mode: Playback speed is -1 times normal speed when the dial is rotated fully counterclockwise, and $+3$ times normal speed when rotated fully clockwise.

Capstan override mode: Rotating the dial while holding down the PLAY button changes the playback speed by up to $\pm 15\%$.

After turning the power on, always center the search dial (where ■ indicator lights).

2-1-4 Lower Control Panel (Time Code Section)

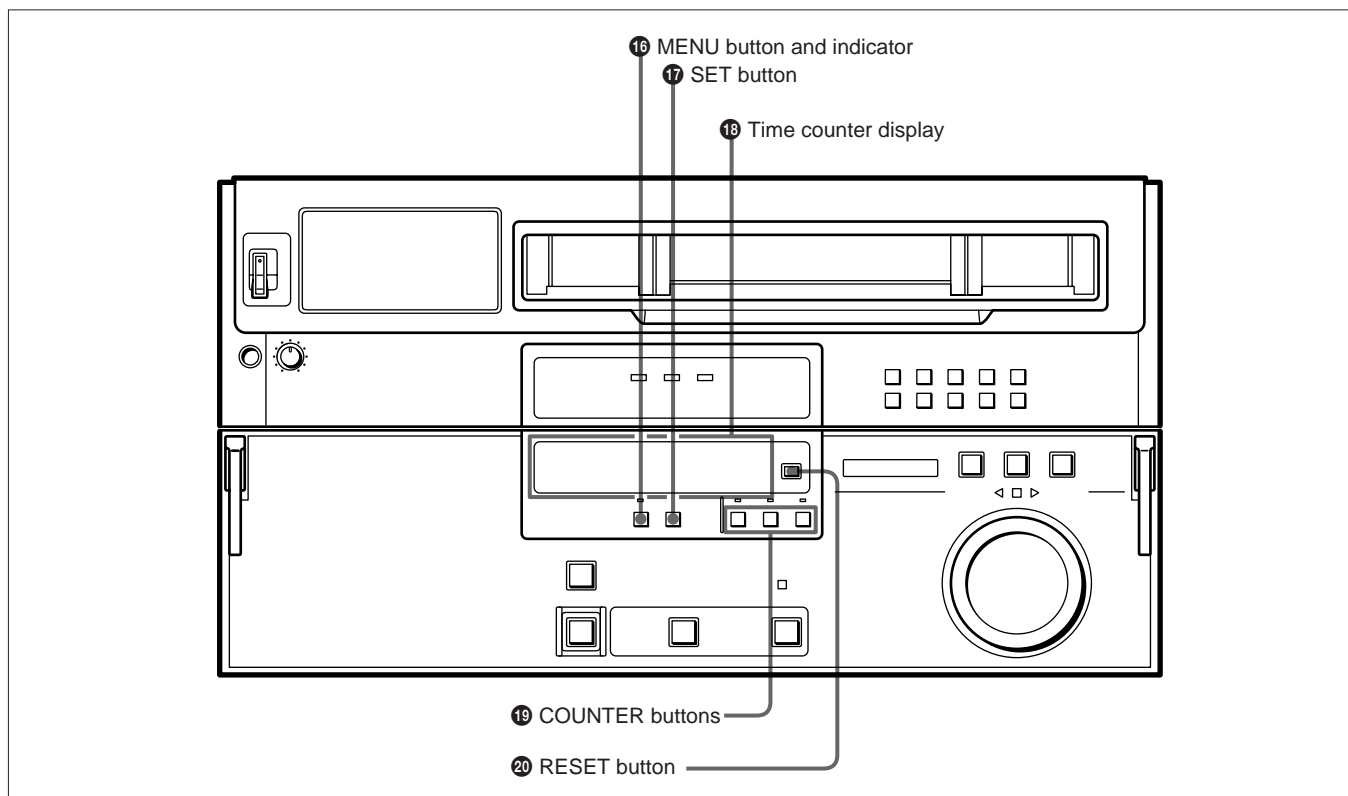

Lower control panel (time code section)

16 MENU button and indicator

When you press this button, the indicator lights and a menu is displayed. When you press this button again, the indicator goes out, and any changes are not saved.

17 SET button

When you press this button after changing one or more items in the menu, those changes are saved.

18 Time counter display

Displays the following time data according to the setting of the time counter display switch.

CTL: Tape running time in hours, minutes, seconds and frames, as determined by counting the CTL signals read from the tape being played back.

TC: Time code being read from the tape by the built-in time code reader. Either the LTC or VITC time code is displayed, according to the setting of the TC selector on the system set-up panel.

U-BIT: User's bits included in the time code being read from the tape. User's bits included in LTC or VITC time codes are displayed, according to the setting of the TC selector on the system set-up panel.

For the meanings of the error codes ("Error-XX") displayed in the time counter display, refer to the Maintenance Manual Part 1.

19 COUNTER buttons

Press one of these buttons according to the type of data to be displayed in the time counter display.

COUNTER buttons, data displayed and editing tape address

The COUNTER button pressed	Data displayed	Editing tape address
U-BIT	User's bits	Time code
TC	Time code	Time code
CTL	CTL	CTL

2-1 Control Panel

②0 RESET button

Resets the time counter as follows, according to the setting of the COUNTER buttons:

CTL: Sets the CTL counter to 00:00:00:00.

TC or U-BIT: No effect.

2-2 System Set-Up Panel

Lift the lower control panel up into its horizontal position to access the system set-up panel.

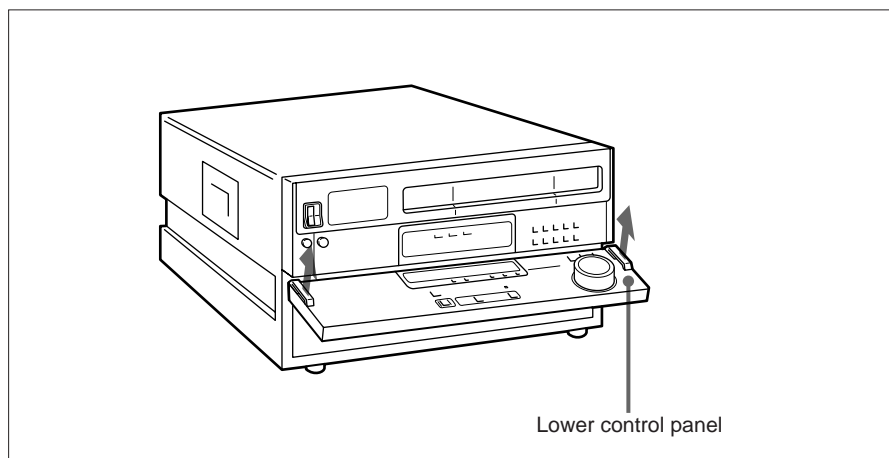

Accessing the system set-up panel

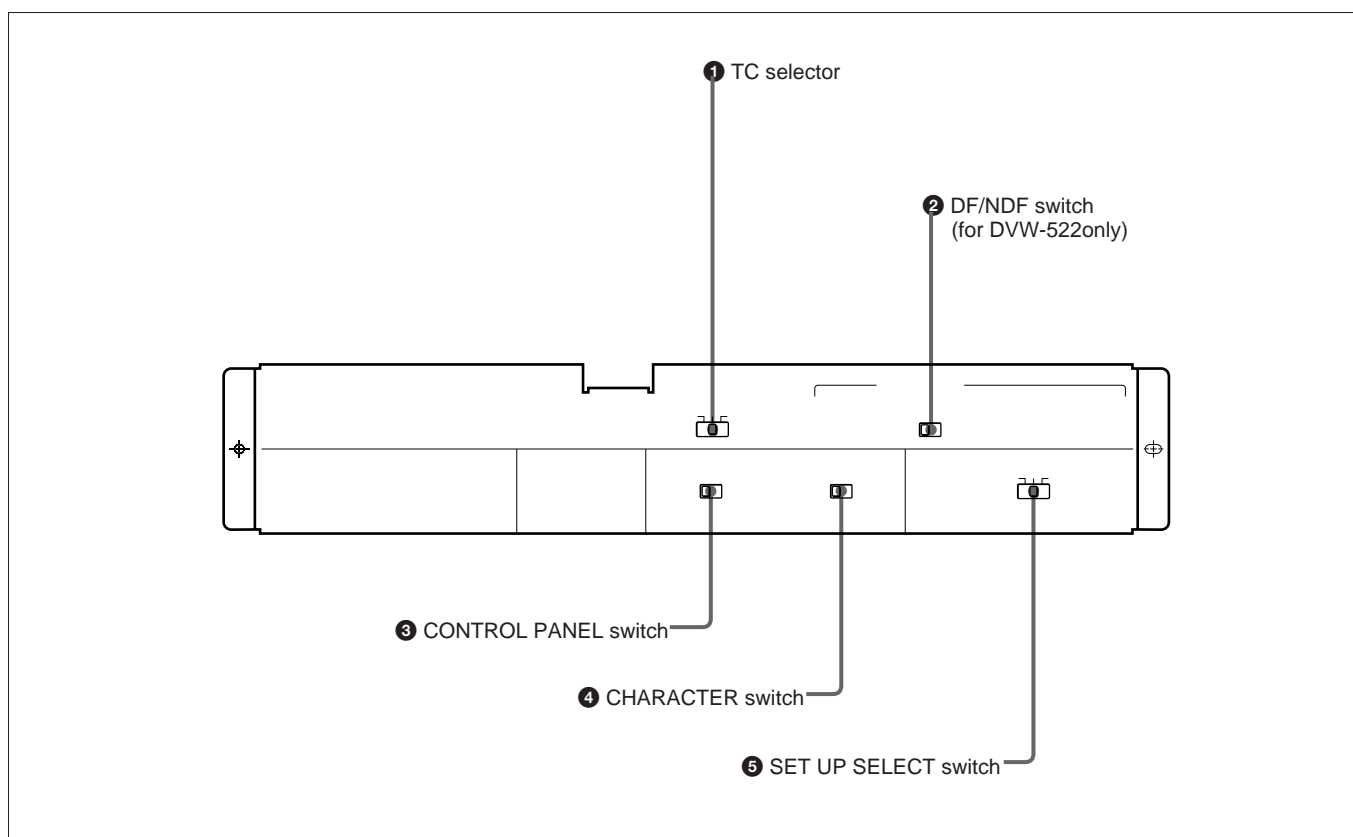

System set-up panel

1 TC (time code) selector

Determines whether the time code displayed in the time counter display on the lower control panel is LTC or VITC. When this switch is set to AUTO, the time counter display shows LTC when the tape speed exceeds $\pm 1/2$ times normal speed, but VITC when the speed is within $\pm 1/2$ times normal speed. This switch is factory set to LTC.

2 DF/NDF (drop-frame/non-drop-frame) switch (for DVW-522 only)

Selects CTL counter advance in drop-frame mode or non-drop-frame mode.

NDF: Non-drop-frame mode.

DF: Drop-frame mode.

This switch is factory set to DF.

2-2 System Set-Up Panel

③ CONTROL PANEL switch

Selects which control panel controls this VTR.

INT: The control panel on the front panel controls this VTR.

EXT: An external control panel, connected through the CONTROL PANEL connector, controls this VTR.

This switch is factory set to INT.

④ CHARACTER switch

Selects whether character signals such as time codes are superimposed on the video signals output from the COMPOSITE VIDEO OUTPUT 2 (SUPER) connector.

ON: Superimposed.

OFF: Not superimposed.

This switch is factory set to ON.

⑤ SET UP SELECT switch

Selects the menu bank used to store set-up menu settings for VTR operation. The VTR is set according to the settings in the selected menu bank.

Pressing the MENU button displays the set-up menu for the selected menu bank in the time counter display and/or on the monitor screen.

For details on the set-up menu, refer to “3-2 Set-Up Menu” on page 3-2 in this manual and the Maintenance Manual Part 1.

2-3 Connector Panel

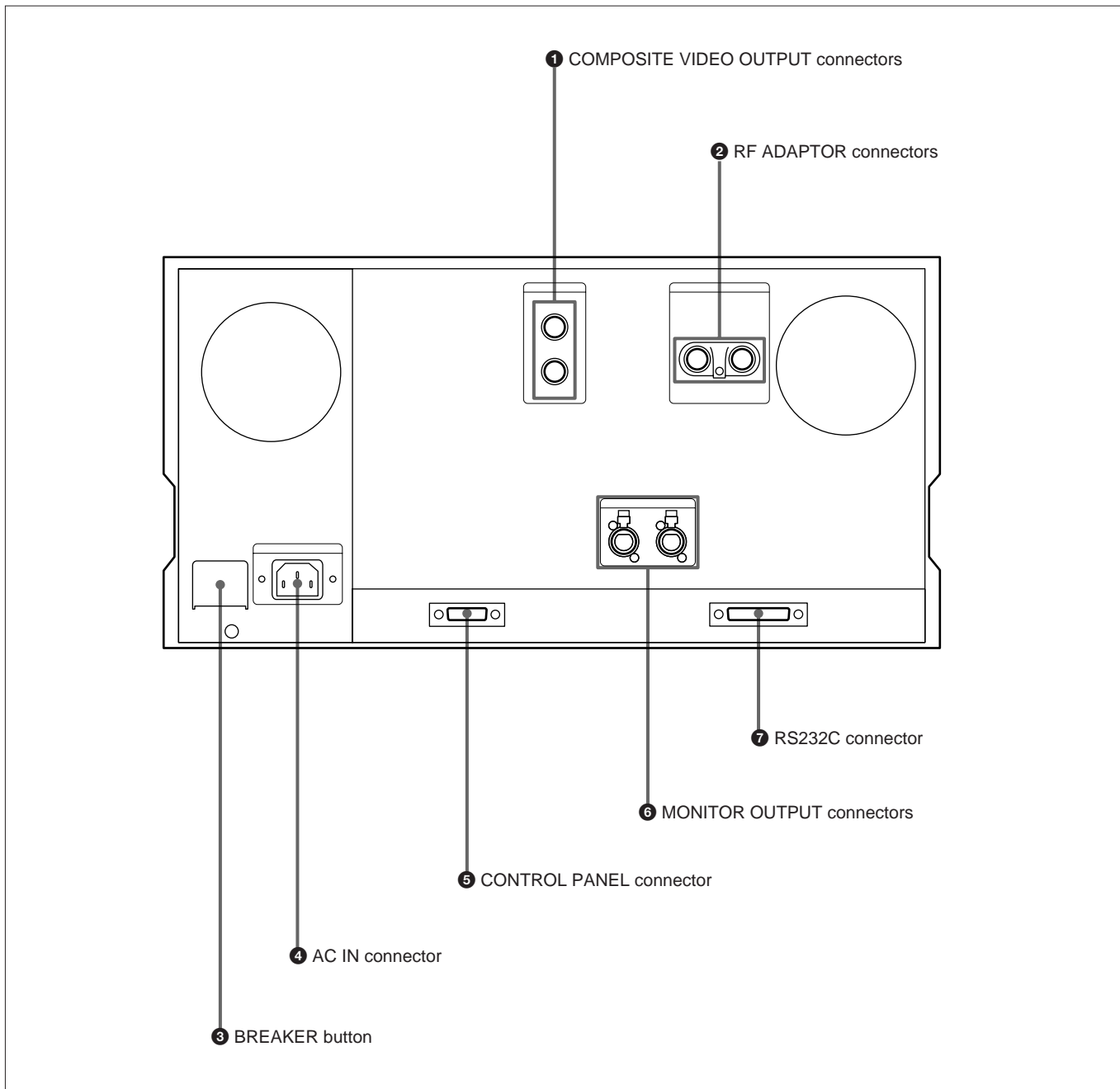

Connector panel

❶ COMPOSITE VIDEO OUTPUT connectors (BNC type)

Output analog composite video signals. When the CHARACTER switch is set to ON, the signal output from connector 2 (SUPER) contains superimposed characters, such as time data or menu setting data.

❷ RF ADAPTOR connectors

By connecting these connectors to an RFU-89UCKA/EKA/ASKA RFU adaptor kit or equivalent equipment, then supplying the resultant RF signal to the antenna terminals of a regular TV set, you can check the video and audio contents of a recorded tape on a regular TV set.

❸ BREAKER button

Disconnects the primary circuit of the AC power transformer when an excessive current surge is detected.

❹ AC IN connector

Connect to an AC outlet using the power cord supplied with the VTR.

2-3 Connector Panel

5 CONTROL PANEL connector (D-sub15-pin)

Connects the control panel through the 15-pin cable supplied in the optional BKDW-510 Control Panel Extension Kit to allow the control panel to be used in a remote control configuration.

6 MONITOR OUTPUT connectors (XLR-3-32)

Output signals to the audio monitor in two signal lines: L and R. The signals to be output are selected with the MONITOR SELECT buttons on the upper control panel.

By selecting the output signals, you can adjust the volume level with the PHONES level control on the upper control panel.

For details, refer to the Maintenance Manual Part 1.

Notes

- If you connect a transformer-less CANNON to PIN converter to the MONITOR OUTPUT connectors to obtain unbalanced output, it is recommended that you change the level of the output signals from +4 dB (standard) to 0 dB beforehand. If the level of the output signal is kept at +4 dB, distortion may occur when the output level is close to full scale.

For details on changing the output signal level, refer to the Maintenance Manual Part 1.

- If you use the converter mentioned above and an RFU adaptor kit at the same time, audio signal-induced beat interference may occur in the video signals output from the RFU adaptor kit.
If you wish to use the converter and the adaptor at the same time, consult with Sony service personnel.

7 RS232C connector (D-sub 25-pin)

Accepts or sends RS-232C remote control signals and/or VTR status data from/to external equipment.

3-1 Connecting External Equipment

The diagram below shows connection of the DVW-522/522P to various types of external equipment.

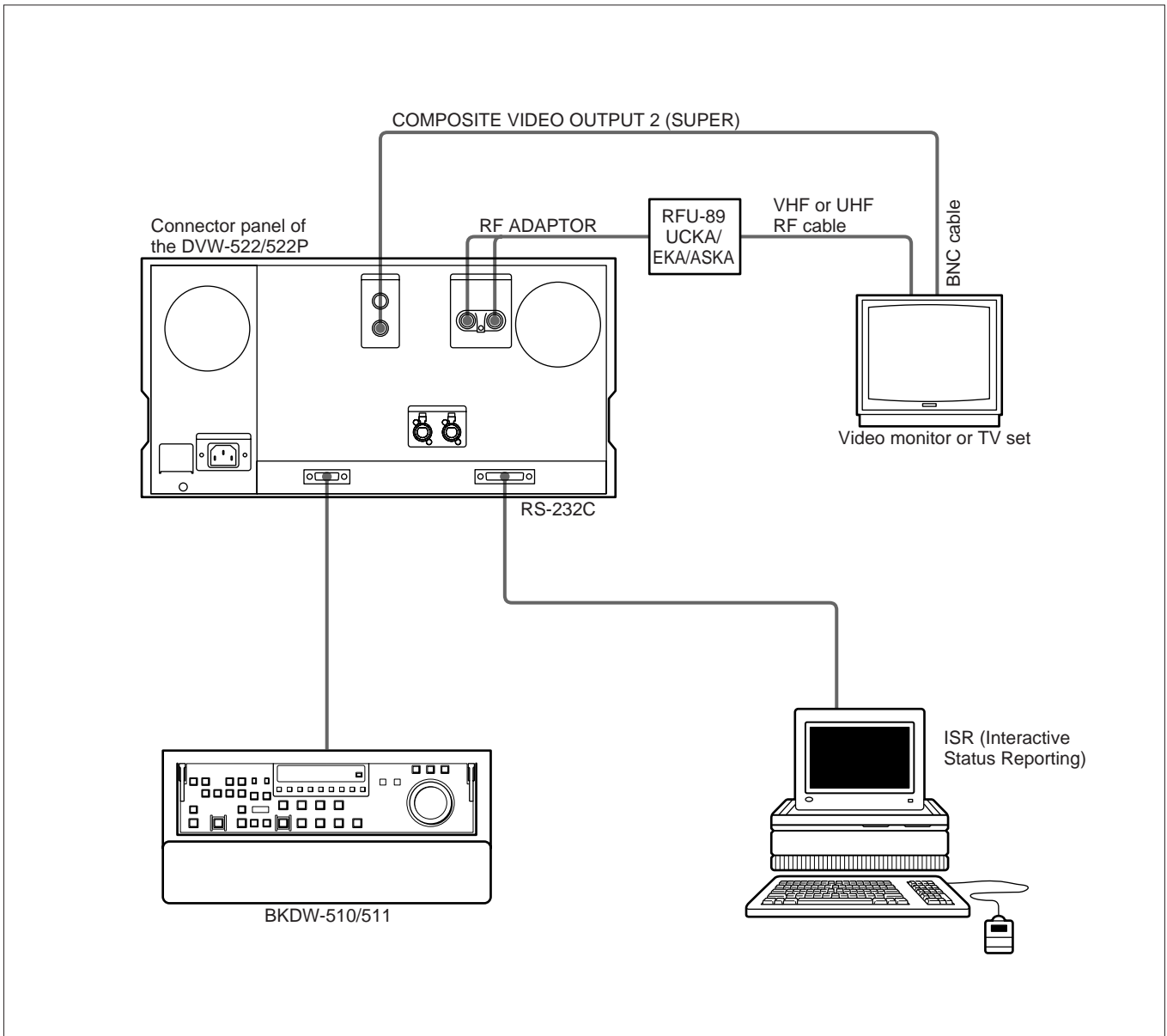

Connecting external equipment

3-2 Set-Up Menu

The set-up menu contains the settings changed most often, such as position and type of the characters superimposed on the output to the monitor. This section describes the items that require setting for operations.

For details on other items not described in this manual, refer to the Maintenance Manual Part I.

3-2-1 Items That Require Setting for Operations

The items that require setting for operations are shown in the table below. The value enclosed in a box is the factory setting.

Items that require setting for operations

Item number	Item	Settable range	Function
002 (DVW-522)	CHARACTER H-POSITION	00 14 24	Sets the horizontal screen position of the superimposed characters. A hexadecimal value of 00 indicates the far left of the screen, and 24 (decimal 36) the far right. Increasing the value moves the starting position to the right.
002 (DVW-522P)	CHARACTER H-POSITION	00 12 22	Sets the horizontal screen position of the superimposed characters. A hexadecimal value of 00 indicates the far left of the screen, and 22 (decimal 34) the far right. Increasing the value moves the starting position to the right.
003 ^{a)} (DVW-522)	CHARACTER V-POSITION	00 56 6A	Sets the vertical screen position of the first line of superimposed characters. A hexadecimal value of 00 indicates the top of the screen, and 6A (decimal 106) the bottom. Increasing the value lowers the position of the characters.
003 ^{a)} (DVW-522P)	CHARACTER V-POSITION	00 6A 81	Sets the vertical screen position of the first line of superimposed characters. A hexadecimal value of 00 indicates the top of the screen, and 81 (decimal 129) the bottom. Increasing the value lowers the position of the characters.
005	DISPLAY INFORMATION SELECT	0 1 2 3 4 5	Determines the kind of information to be displayed as superimposed characters. 0: Time counter display information and VTR status. 1: Time counter display information and user's bits. 2: Time counter display information and CTL. 3: Time counter display information and time code (LTC or VITC). 4: Time code (LTC or VITC) only. 5: "R" (replay) is displayed during DT playback mode.
007	TAPE TIMER DISPLAY	0 1	Determines whether the CTL counter should display a 12-hour or 24-hour clock. 0: 12-hour clock. 1: 24-hour clock.
009	CHARACTER TYPE	0 1 2 3	Determines the type of superimposed characters. 0: White letters on a black background. 1: Black letters on a white background. 2: White outline letters. 3: Black outline letters.

a) As the displayed time code data may be delayed by one frame when inserted in the upper half of the picture due to delay of its display, you must be careful in case of dubbing an off-line editing tape.

Items that require setting for operations (continued)

Item number	Item	Settable range	Function
011	CHARACTER V-SIZE	01 02 03 04	Determines the vertical size of superimposed characters. 01: Standard size. 02: Two times standard size. 03: Three times standard size. 04: Four times standard size.
012	CONDITION DISPLAY ON VIDEO MONITOR	0 1	Determines whether or not to include the display of the channel condition with the superimposed characters. 0: Does not display the condition. 1: Displays the condition. How the channel condition is displayed The condition is displayed below the timer or status line of the characters. (The entire area for displaying the condition is blank when an analog tape is inserted.) Example: V---- A---- The four characters following "V" indicate each video channel condition between Ach and Dch of the rotary head. The four characters following "A" indicate each audio channel condition between Ach and Dch of the rotary head. Character pattern (Space): Status in which no condition is indicated on the front panel. (STBY OFF, etc.) - : The condition is good. (The green indicator lights up.) * : The condition is less than good. (The yellow indicator lights up.) ■ : The condition is bad. (The red indicator lights up.)
101	SELECTION FOR SEARCH DIAL ENABLE	0 1	Determines how the unit enters search mode. 0: The unit enters search mode when you rotate the search dial in all modes. 1: The unit enters search mode when you press the SHUTTLE, JOG or VAR button.
116	JOG DIAL RESPONSE	0 1 2	Determines the tape speed (VTR command) characteristics which correspond to the JOG dial rotation. 0: Tape speed changes linearly in a range of -1 to +1 times normal tape speed. 1: Tape speed changes in steps in a range of -3 to +3 times normal tape speed as shown below in TYPE 2. (Tape speed does not change when the JOG dial is in a range of ±1 times normal tape speed.) 2: Tape speed changes linearly in a range of -3 to +3 times normal tape speed as shown below in TYPE 3. <div style="display: flex; justify-content: space-around;"> <div style="text-align: center;"> <p>TYPE2</p> </div> <div style="text-align: center;"> <p>TYPE3</p> </div> </div>

3-2 Set-Up Menu

Items that require setting for operations (continued)

Item number	Item	Settable range	Function
713	VIDEO SETUP REFERENCE LEVEL (DVW-522 only)		Determines the amount of video setup to be added to composite output signal. When sub-item No.5 OUTPUT LEVEL is set to MASTER, the same amount of setup selected with sub-item No.1 MASTER LEVEL (within a range of 0.0% to 10.0%) is added to the composite output signal. The setup level determined in this item has no relation with the SET UP SELECT switch on the system set-up panel. Note Sub-item No.2 to 4 are prohibited to use.
	Sub-item		
	1 MASTER LEVEL	1 (0.0%) 10 (7.5%) 15 (10.0%) (in 0.5% steps)	
	2 INPUT LEVEL	—	
	3 VBLK REMOVE CNT	—	
	4 BATACAM PB LEVEL	—	
5 OUTPUT LEVEL	0 (MASTER) 1 (0.0%) 15 (10.0%) (in 0.5% steps)		

About the digital hours meter

The menu also includes items related to the digital hours meter (item numbers H01 to H14).

You can specify the superimposition of hours meter information on the monitor screen through the set-up menu. The hours meter provides seven kinds of information concerning the operational history of the VTR, which you can use as a guide for scheduling periodic maintenance.

About the digital hours meter

Item number	Item	Function
H01	OPERATION HOURS	Displays the total number of hours in ten-hour units that the VTR has been in operation, with the power turned on. Note The accumulated power ON time is displayed in one-hour units on the timer counter display while the JOG or SHUTTLE button on the lower control panel is pressed. On the monitor screen, however, it is displayed in one-hour units without pressing the JOG or SHUTTLE button.
H02	DRUM RUNNING HOURS	Displays the total number of hours in ten-hour units that the drum has rotated with tape threaded. Note The accumulated drum running hours are displayed in one-hour units on the timer counter display while the JOG or SHUTTLE button on the lower control panel is pressed. On the monitor screen, however, it is displayed in one-hour units without pressing the JOG or SHUTTLE button.

About the digital hours meter (continued)

Item number	Item	Function
H03	TAPE RUNNING HOURS	Displays the total number of hours in ten-hour units that the VTR has been in playback and search modes. (Does not include stop and still modes.) Note The accumulated tape running hours are displayed in one-hour units on the timer counter display while the JOG or SHUTTLE button on the lower control panel is pressed. On the monitor screen, however, it is displayed in one-hour units without pressing the JOG or SHUTTLE button.
H04	THREADING COUNTER	Displays the total threadings and unthreadings in ten-cycle units. Note The accumulated number of the threading and unthreading cycles are displayed in the actual number of cycles on the timer counter display while the JOG or SHUTTLE button on the lower control panel is pressed. On the monitor screen, however, it is displayed in the actual number of cycles without pressing the JOG or SHUTTLE button.
H12	DRUM RUNNING HOURS (resettable)	Displays the total number of hours in ten-hour units that the drum has run with tape threaded since last reset. Use this information as a guide for head-drum replacements. <i>For details, refer to the Maintenance Manual Part 1.</i>
H13	TAPE RUNNING HOURS (resettable)	Displays the total number of hours in ten-hour units that the VTR has been in playback and search modes since last reset. (Does not include stop and still modes.) Use this information as a guide for replacing the fixed head and pinch rollers. <i>For details, refer to the Maintenance Manual Part 1.</i>
H14	THREADING COUNTER (resettable)	Displays the total threadings and unthreadings in ten-cycle units since last reset. <i>For details, refer to the Maintenance Manual Part 1.</i>

Reading hours meter information

Follow the procedure below to read hours meter information.

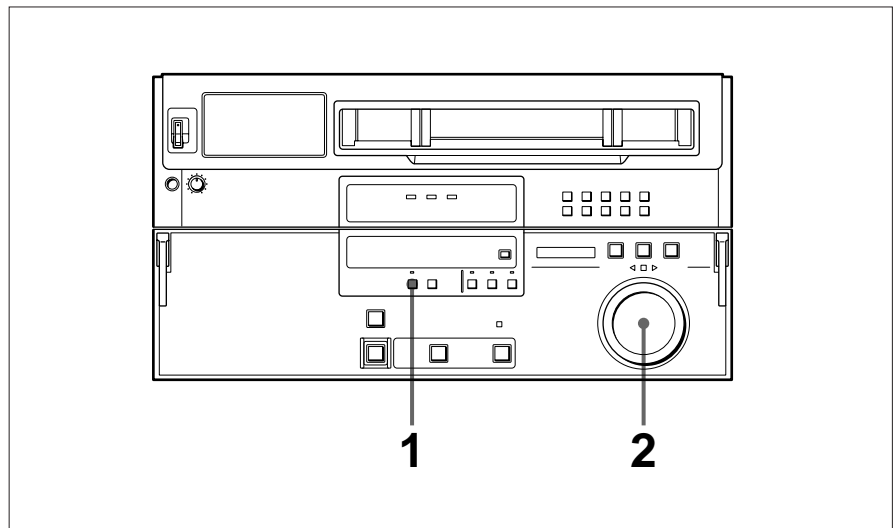

Reading hours meter information

- 1 Press the MENU button to display the hours meter (H01) in the time counter display.
If another previously selected menu item appears, press the TC button in the time counter display section to display H01.

(continued)

- 2 Rotate the search dial to select the hours meter information you want to display.

The selected information appears in the time counter display.

Notes

Hours meter values are normally displayed in four digits, in units of ten hours or ten cycles.

By pressing the JOG or SHUTTLE button, hours meter values are displayed in six digits in units of hours or cycles.

- Hours meter information also appears on the monitor screen in units of hours (six-digit format) whether you press the JOG or SHUTTLE button or not.

To return to the counter display

Press the MENU or SET button.

Item to be set only during tracking adjustments

Item F13 is set only during tracking adjustments. It is therefore normally not displayed in the menu to prevent erroneous setting. To display this item, follow the procedure below.

Preparation

Follow the procedure in “Changing the setting of items in a customized menu” on page 3-11 to change the setting of item F13.

Operation

To display item F13 in the set-up menu, rotate the search dial while pressing the PLAY button on the lower control panel.

Note

Item F13 is used exclusively for adjustment. After adjustment is completed, the item should be returned to its factory setting.

Item to be set only during tracking adjustments

Item number	Item	Settable range	Function
F13	TRACKING CONTROL VIA SEARCH DIAL	0 1	Selects whether tracking control operations with the search dial are enabled or not during DT head playback. This item is provided exclusively for DT adjustment and tracking adjustments. After the adjustment is completed, return the item to the factory setting '0 (off)'. 0: Tracking control function is disabled during DT head playback. 1: Tracking control function is enabled by rotating the search dial during playback mode.

3-2-2 Changing Menu Settings

This section describes how to change the factory-set values for each menu setting.

Menu display after changing a menu setting

The [C] mark appears in the monitor display when you change a factory setting in a customized menu.

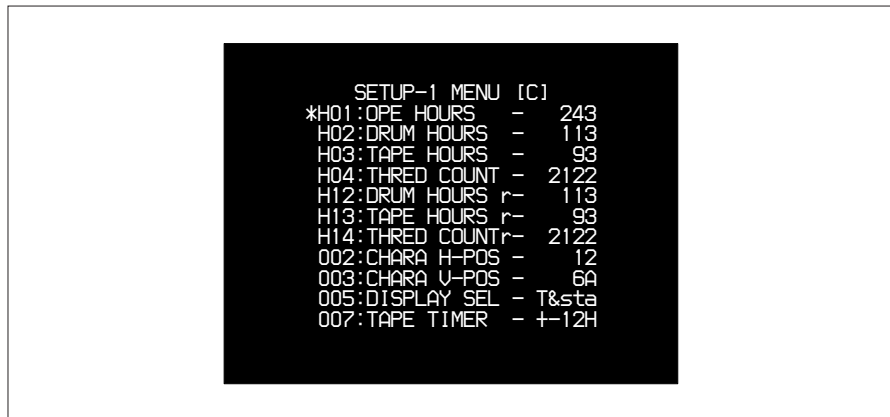

Menu display after changing a menu setting

Note

The [C] mark indicates that only a part of the full menu is being shown through the unit's customize function.

Changing menu settings

When the CHARACTER switch on the system set-up panel is set to ON, the set-up menu contents appear on the time counter on the control panel and on the video monitor connected to the COMPOSITE VIDEO OUTPUT 2 (SUPER) connector. The menu contents consist of item number, sub-item number, and data number.

To change the factory-set values of the menu items, follow the procedure on next page.

Note

Before starting this procedure, No.1 on DIP switch S100 on the SS-52 board needs to be set to ON.

Consult the qualified service personnel for DIP switch settings.

3-2 Set-Up Menu

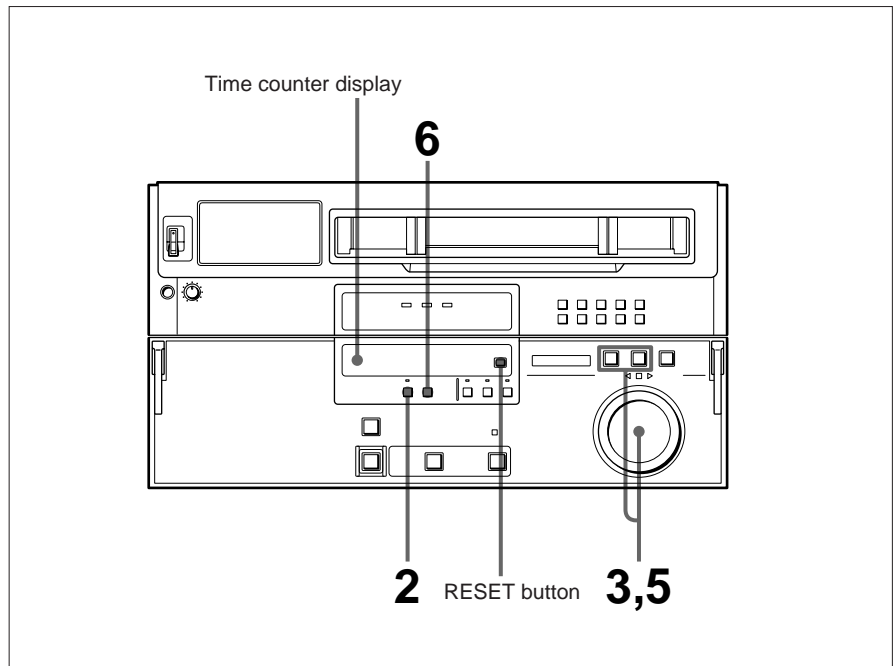

Changing menu settings

- 1** Select the menu bank with the SET UP SELECT switch on the system set-up panel.
- 2** Press the MENU button to display the menu in the time counter display.



Monitor display

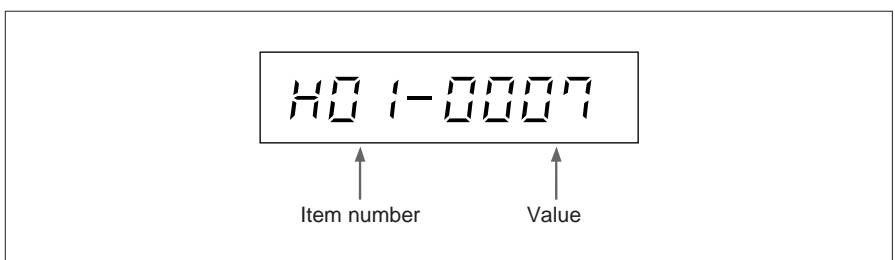

Time counter display

3 Rotate the search dial to select the item to be changed.

The item number increases as you rotate the search dial clockwise, or decreases as you rotate the dial counterclockwise. Search dial operation is the same when searching for a certain tape position in both shuttle and jog modes.



Monitor display

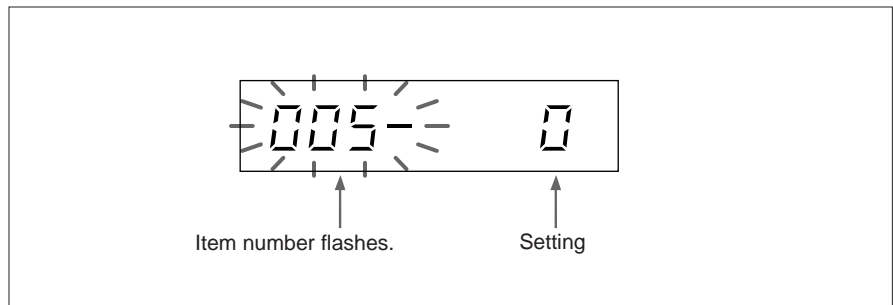

Time counter display

4 Item 713 comprises multiple sub-items, each of which must be set individually.

For details, refer to "Setting sub-items" on page 3-10.

To change the setting of the ITEM-F00 SERIES, refer to "Changing the setting of items in a customized menu" on page 3-11.

(continued)

3-2 Set-Up Menu

- 5 To change the setting, rotate the search dial while holding down the SHUTTLE or JOG button. When you have reached the required value, release the button.

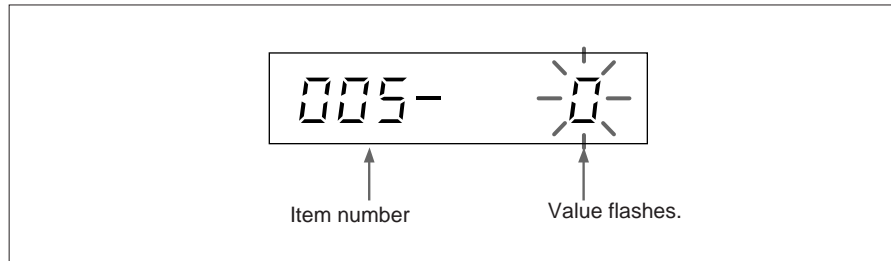

Time counter display



Monitor display

- 6 Repeat Steps 3 through 5 to change other items.

To cancel the setting and return to the original settings, press the MENU button.

- 7 To save your changes, press the SET button.

Setting sub-items

- 1 Select item 713 in Step 3 on page 3-9.

The sub-item number is displayed in the seconds display, and the current setting is displayed in the frame display in the time counter.

- 2 Rotate the search dial while holding down the STOP button to select the sub-item to be set.

- 3 Rotate the search dial while holding down the SHUTTLE or JOG button to change the setting.

The selected sub-item is highlighted.

Restoring factory-set values

Follow the procedure below to restore the factory-set values.

- 1** Press the SET UP SELECT switch on the system set-up panel to select the menu bank whose values are to be reset.
- 2** Press the MENU button to display the menu in the time counter display.
- 3** Press the RESET button in the time counter display section.

Changing the setting of items in a customized menu

The factory settings of items H01 to H14 and items 001 to 713 are displayed in set-up menu mode; however, item F13 (used exclusively for adjustment) is not normally displayed.

The unit's customize function allows you to select specific items for display in set-up menu mode.

Follow the procedure below to change the settings of items selected for the customized menu.

Note

Before starting this procedure, No.1 and No.5 on DIP switch S100 on the SS-52 board need to be set to ON.

Consult the qualified service personnel for DIP switch settings.

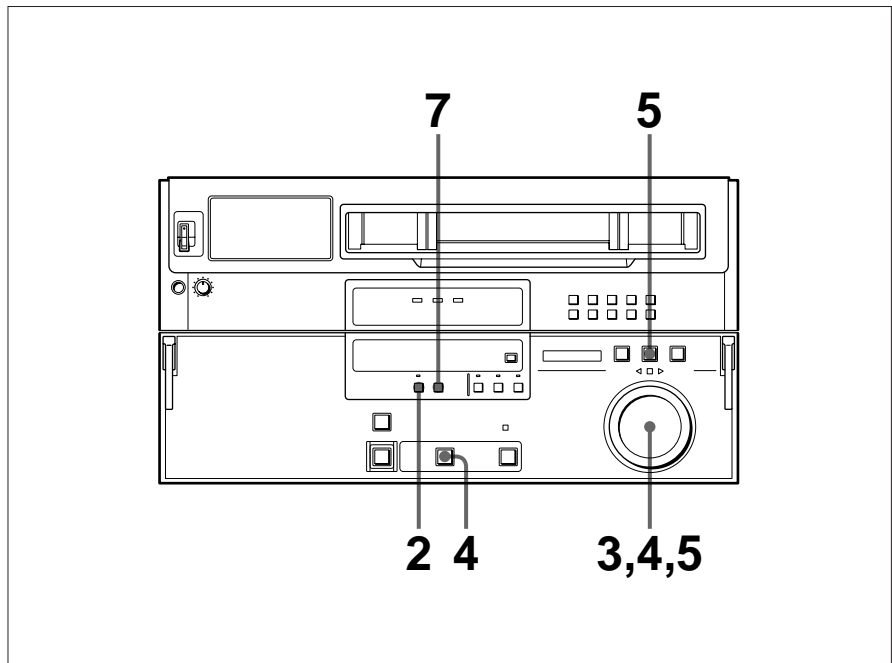

Changing the setting of items in a customized menu

- 1** Select the menu bank to be changed with the SET UP SELECT switch on the system set-up panel.

(continued)

3-2 Set-Up Menu

- 2 Press the MENU button for more than three seconds to enter the customize menu mode.

At first, the monitor display enters set-up menu mode and then turns over to the customize menu mode on a white background.

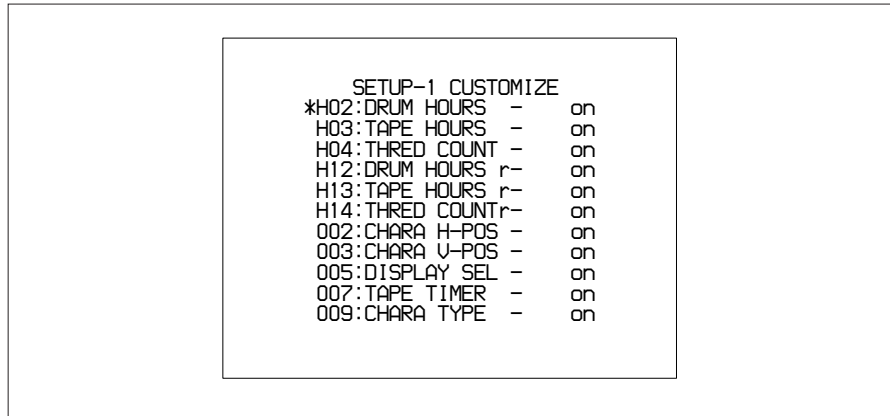

Monitor display

- 3 Rotate the search dial to select the item to be changed.

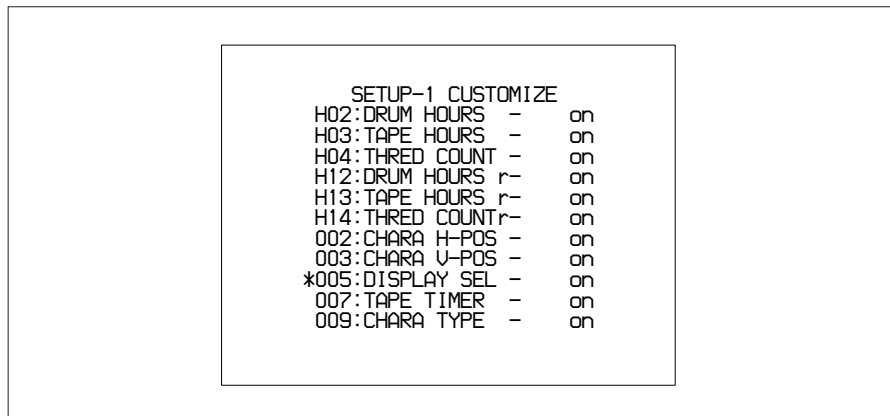

Monitor display

- 4 To select the item F13, rotate the search dial while holding down the PLAY button.

- 5** To change a customize menu data, rotate the search dial while holding down the JOG button.

Each item is displayed individually while holding down the JOG button.

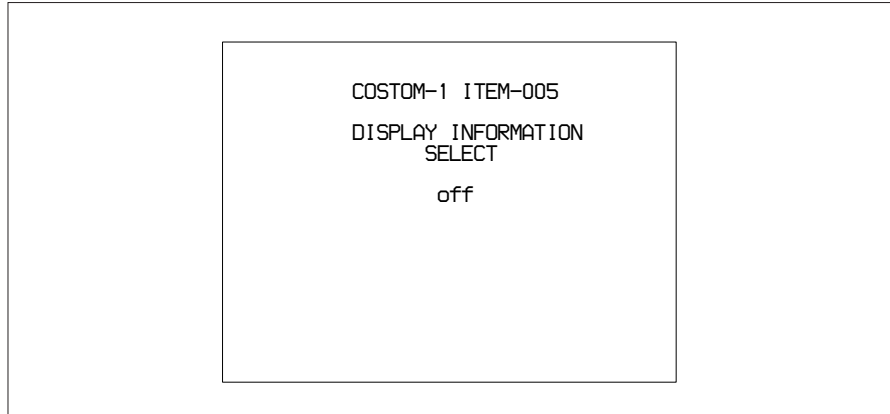

Monitor display

Data number	Data	Description
0	on	0 (on): The item is displayed in the set-up menu mode.
1	off	1 (off): The item is not displayed in the set-up menu mode.

- 6** Repeat Steps **3** through **5** to change other item data.

To cancel the setting and return to the original settings, press the MENU button.

- 7** To save your changes, press the SET button.

Note

The changes that you made are not saved unless you press the SET button.

To return to the factory setting values

Press the RESET button.

3-3 Superimposed Characters

If you set the CHARACTER switch on the system set-up panel to ON, messages indicating the time codes and operation modes are superimposed on the signals output from the COMPOSITE VIDEO OUTPUT 2 (SUPER) or RF ADAPTOR connector.

Adjusting the character display

You can use the set-up menu to set the position, size and type of the superimposed characters.

For details, refer to “3-2 Set-Up Menu” on page 3-2.

Information displayed

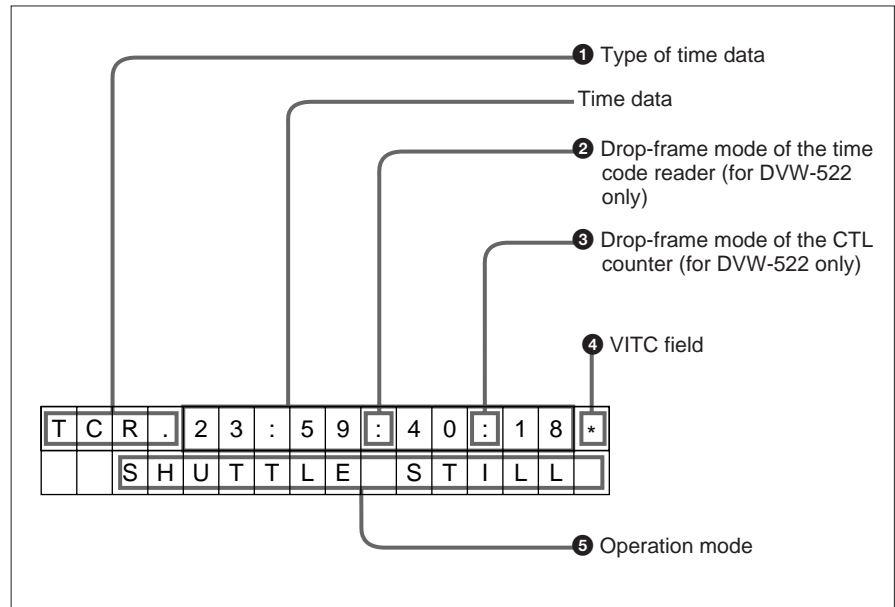

Displayed information

1 Types of time data

Types of time data

Display	Meaning
CTL	CTL counter data
TCR	LTC reader time code
UBR	LTC reader user's bits
TCR.	VITC reader time code
UBR.	VITC reader user's bits

Note

When the time data or user's bits is not read correctly, it is displayed with an asterisk. For example, “T*R”, “U*R”, “T*R.” or “U*R.”.

2 Drop-frame mode of the time code reader (for DVW-522 only)

3 Drop-frame mode of the CTL counter (for DVW-522 only)

“.”: Drop-frame mode (factory setting).

“:”: Non-drop-frame mode.

4 VITC field

“ ” (blank): Fields 1 and 3.

“*”: Fields 2 and 4.

5 Operation Mode

A field is divided into two blocks, A and B.

- Block A displays the operation mode.
- Block B displays the servo lock status or tape speed.

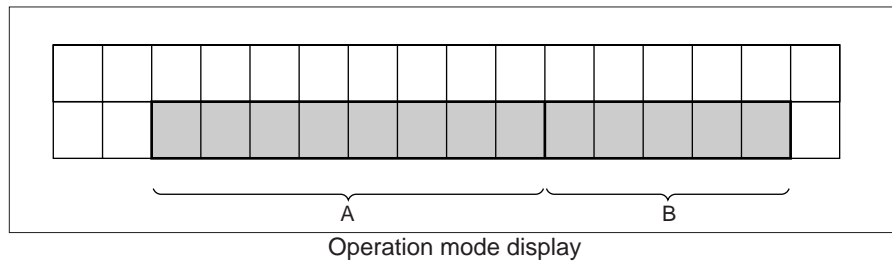

Operation mode messages

Message		Operation mode
Block A	Block B	
TAPE UNTHREAD		Displayed from the time the EJECT button is pressed and the cassette is ejected until another cassette is inserted.
STANDBY OFF		Standby-off mode
STOP		Stop mode
PLAY		Playback mode (servo unlocked)
PLAY	LOCK	Playback mode (servo locked)
PLAY	Deviation from normal speed (%)	Capstan override mode
JOG	STILL	Still-picture in jog mode
JOG	FWD	Jog mode in forward direction
JOG	REV	Jog mode in reverse direction
SHUTTLE	(Speed)	Shuttle mode
VAR	(Speed)	Variable mode

3-4 Handling Cassettes

3-4-1 Recommended Cassettes

You can use 1/2 -inch Digital BETACAM video cassettes only.

Digital BETACAM cassettes

S (small) cassettes	BCT-D6/D12/D22/D32/D40
L (large) cassettes	BCT-D34L/D64L/D94L/D124L

Storage of cassettes

Store your cassettes at ambient temperature and humidity.

3-4-2 Inserting and Ejecting Cassettes

Always turn on the power of the VTR before attempting to insert or eject cassettes.

Inserting a cassette

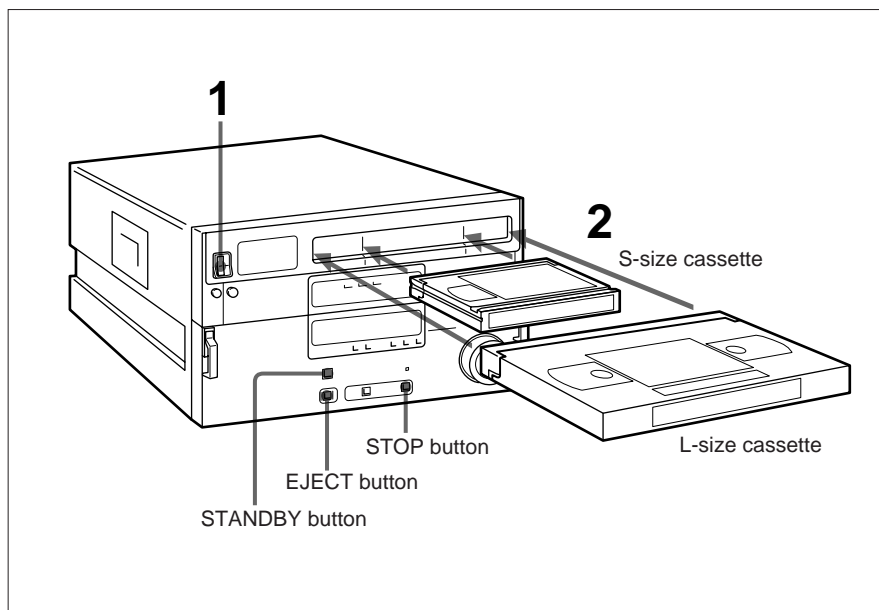

Inserting a cassette

- 1** Set the POWER switch to ON.
- 2** Before inserting the cassette, verify the following:
 - There is no slack in the tape.
 - “Error-10” is not displayed in the time counter display.
 - The window of the cassette is facing up.

If there is any slack in the tape, refer to “Removing slack in the tape” on next page. If “Error-10” is displayed in the time counter display, refer to “5-2 Moisture Condensation” on page 5-2.

When inserting a small cassette, align it with the marks on the cassette insertion slot.

The cassette is loaded automatically, and the tape is wound around the drum. The head-drum starts to rotate, the tape stops, and the **STANDBY** and **STOP** buttons light.

When a **BETACAM/BETACAM SP** video cassette is loaded, the tape is automatically ejected.

Removing slack in the tape

Press one of the reels in slightly, then carefully rotate it in the direction of the arrow until it stops.

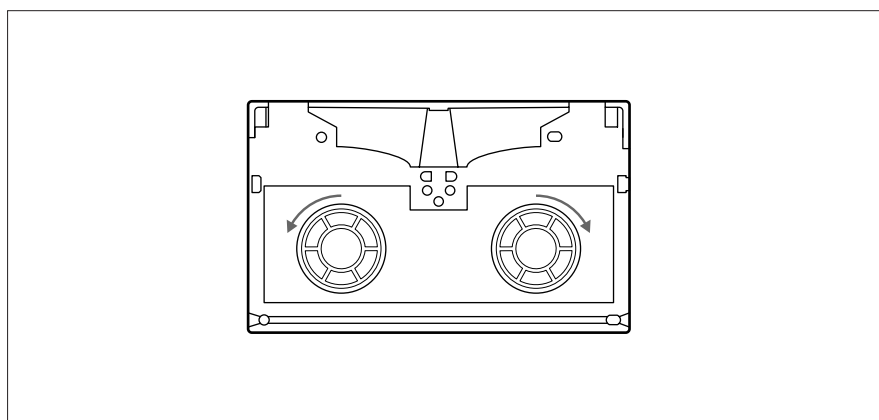

Removing slack in the tape

Preventing double cassette insertion

When a cassette is loaded, an orange lock-out bar appears in the cassette insertion slot to prevent users from attempting to load another cassette.

Ejecting a cassette

Press the **EJECT** button.

The tape is unthreaded and the cassette is automatically ejected.

This operation takes a few seconds.

Removing a cassette when tape slacking has occurred

For details, refer to the Maintenance Manual Part 1.

4-1 Preparing for Playback

4-1-1 Setting Switches

Before starting playback, set the switches as follows.
For details, refer to the pages indicated in parentheses.

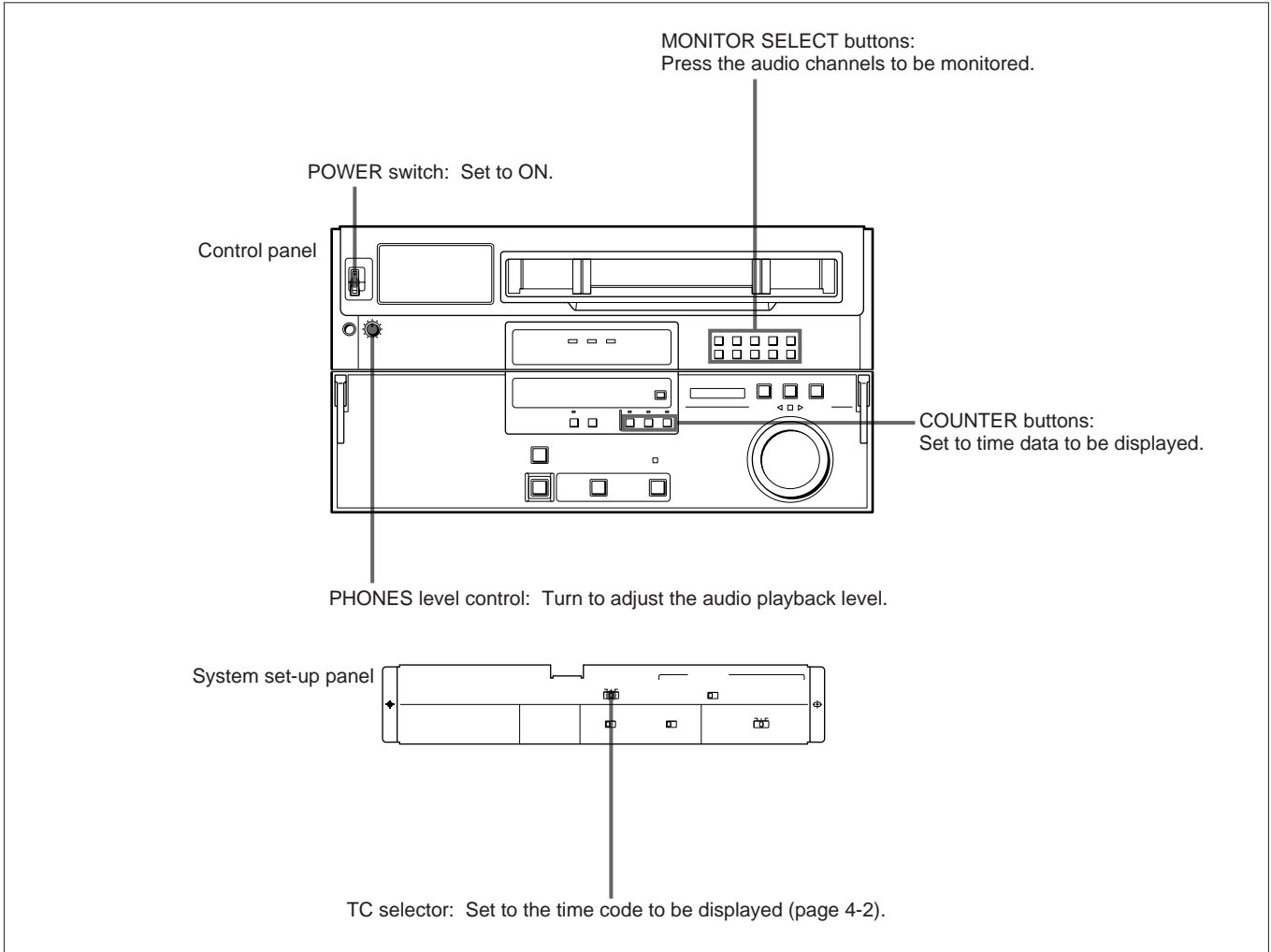

Switch settings for playback

4-1 Preparing for Playback

4-1-2 Selecting Time Data to Be Displayed

You can select any of the following types of time data for display on the time counter display.

- CTL counter data
- Time codes
- User's bits

For details on the location of the switches used in the following operations, refer to "4-1-1 Setting Switches" on the previous page.

Displaying CTL counter data

Press the CTL button on the lower control panel.

The VTR counts the CTL signals recorded on the tape and displays the tape running time in hours, minutes, seconds and frames.

Resetting the display

Press the RESET button in the time counter display section.

The value is reset to "0:00:00:00". A minus sign appears if the tape is rewound from that position.

Displaying time codes

Press the TC button on the lower control panel.

To select the type of time code to be displayed, set the TC selector on the system set-up panel as follows:

LTC: LTC

AUTO: • VITC if the playback speed is within $\pm 1/2$ times normal speed.
• LTC if the playback speed exceeds $\pm 1/2$ times normal speed.

VITC: VITC

The VITC or LTC indicator on the upper control panel lights to indicate the type of time code recorded on the tape.

Displaying user's bits

Press the U-BIT button on the lower control panel.

As when displaying time codes, user's bits contained in either LTC or VITC time codes are displayed according to the setting of the TC selector on the system set-up panel.

4-2 Playback

The DVW-522/522P supports three playback modes:

- Normal-speed playback
- Jog/Shuttle/Variable mode playback
- Capstan override playback

4-2-1 Normal-Speed Playback

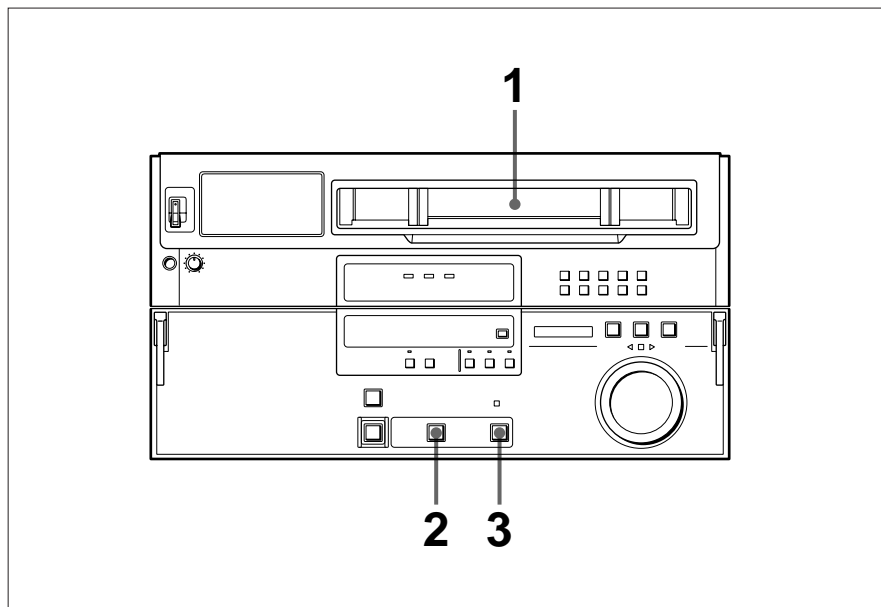

Playing back at normal speed

Follow the procedure below to play back at normal speed.

- 1** Insert the cassette.

For details, refer to “3-4-2 Inserting and Ejecting Cassettes” on page 3-16.

- 2** Press the PLAY button.

Playback starts and the SERVO indicator lights to show that the servo is locked.

- 3** Press the STOP button to stop playback.

If playback continues to end of the tape

The VTR automatically rewinds the tape to the beginning and stops.

4-2 Playback

4-2-2 Variable-Speed Playback in Jog/Shuttle/Variable Modes

In the Jog/Shuttle/Variable modes, you can vary the playback speed as follows:

Jog mode: Between -3 and $+3$ or between -1 and $+1$ (selectable in the set-up menu) times normal speed, as determined by the rotational speed of the search dial.

Shuttle mode: Between -50 and $+50$ times normal speed, as determined by the angle of rotation of the search dial.

Variable mode: Between -1 and $+3$ times normal playback speed, as determined by the angle of rotation of the search dial.

Jog mode playback

Follow the procedure below to play back in jog mode.

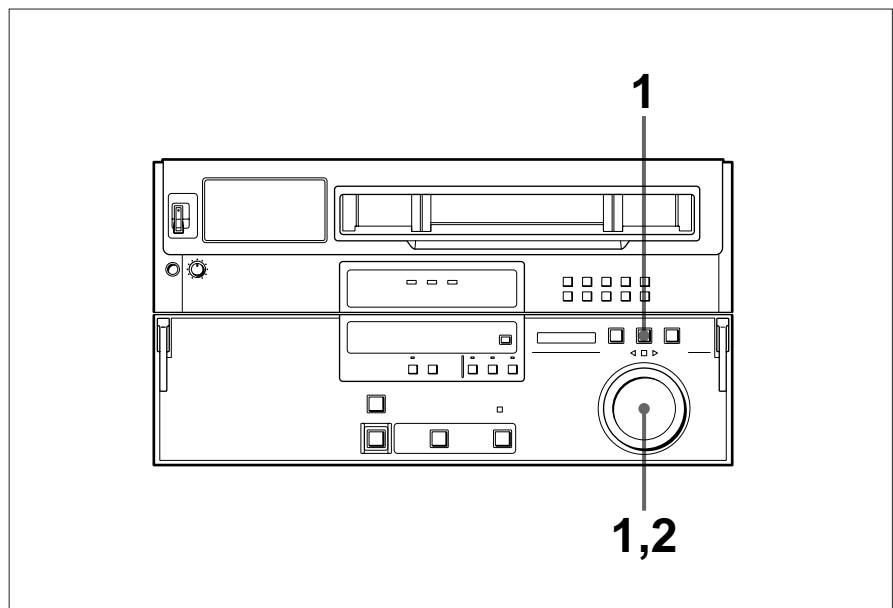

Jog mode playback

- 1** Press the search dial or the JOG button so that the JOG indicator lights.

Each time you press the dial, the VTR toggles between jog mode and shuttle mode. The JOG or SHUTTLE indicator lights to indicate the selected mode.

The ■ indicator lights and the VTR enters still-picture mode.

- 2** Rotate the search dial in the direction of playback.

The playback speed corresponds to the rotational speed of the search dial. One of the direction indicators (◀ or ▶) lights to show the direction of playback.

- 3** To stop jog mode playback, stop rotating the search dial (the ■ indicator lights), or press the STOP button for stop mode.

Note

The search dial is factory set to toggle between jog and shuttle modes when pressed. You can, however, cancel this setting.

For details, refer to “3-2-1 Items That Require Setting for Operations” on page 3-2.

Shuttle mode playback

Follow the procedure below to play back in shuttle mode.

- 1 Push in the search dial or the SHUTTLE button so that the SHUTTLE indicator lights.

Each time you press the dial, the VTR toggles between jog mode and shuttle mode. The JOG or SHUTTLE indicator lights to indicate the selected mode.

The ■ indicator lights and the VTR enters still-picture mode.

Whenever you turn the VTR on, always set the search dial to the center position, so that the ■ indicator lights.

- 2 Rotate the search dial in the direction of playback until the angle of rotation corresponds to the playback speed that you want.

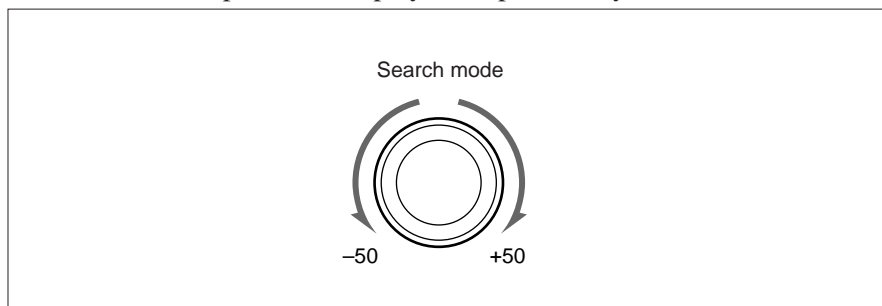

The playback speed corresponds to the angle of rotation of the search dial. One of the direction indicators (◀ or ▶) lights to show the direction of playback.

The search dial clicks at positions corresponding to -10, 0, and +10 times normal speed.

- 3 To stop shuttle mode playback, set the search dial to the center position for still-picture, or press the STOP button for stop mode.

To return to normal-speed playback

Press the PLAY button.

To alternate between normal-speed playback and shuttle-mode playback

After setting the search dial to the required playback speed, press the PLAY button and SHUTTLE button alternately to switch between normal-speed playback and shuttle-mode playback.

To stop and start shuttle-mode playback, press the STOP button and SHUTTLE button respectively.

Note

The search dial is factory set to start jog or shuttle mode playback in all other operation modes whenever you rotate the dial.

For details on cancelling this factory setting and making it a requirement to press the JOG/SHUTTLE/VAR button to start Jog/Shuttle/Variable mode playback, refer to “3-2-1 Items That Require Setting for Operations” on page 3-2.

Variable mode playback

Follow the procedure below to play back in variable mode.

- 1 Press the VAR button so that the VAR button lights.

The ■ indicator lights and the VTR enters still-picture mode.

Whenever you turn on the VTR, always set the search dial to the center position, so that the ■ indicator lights.

- 2 Rotate the search dial in the direction of playback until the angle of rotation corresponds to the playback speed that you want.

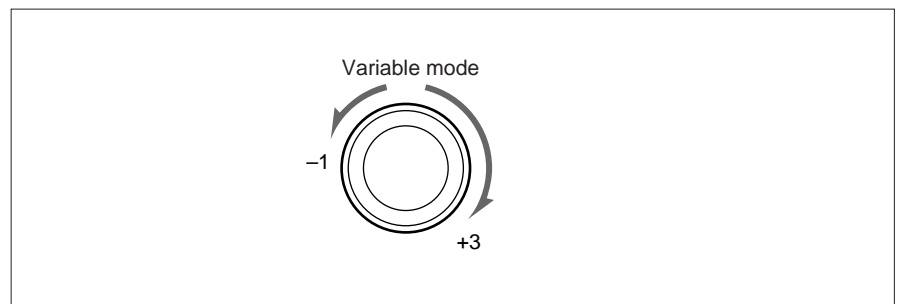

The playback speed corresponds to the angle of rotation of the search dial. One of the direction indicators (◀ or ▶) lights to show the direction of playback.

The search dial clicks at the positions for still-picture and normal-speed playback.

- 3 To stop variable-mode playback, set the search dial to the center position for still-picture, or press the STOP button for stop mode.

To return to normal-speed playback

Press the PLAY button.

To alternate between normal-speed playback and variable-mode playback

After setting the search dial to the required playback speed, press the PLAY button and VAR button alternately to switch between normal-speed playback and variable-mode playback.

To stop and start variable-mode playback, press the STOP button and VAR button respectively.

4-2-3 Capstan Override Playback

When playing back the same program on two VTRs, the playback phases of the two VTRs can be adjusted so that they are synchronized with each other. However, since there are no reference signal connectors on the VTRs, complete synchronization between the two VTRs cannot be obtained.

Note

Set the system so that jog/shuttle mode playback does not start unless you press the JOG, SHUTTLE or VAR button first. Doing this prevents the VTR from accidentally entering search mode during capstan override playback.

For details on setting the system in this way, refer to “3-2-1 Items That Require Setting for Operations” on page 3-2.

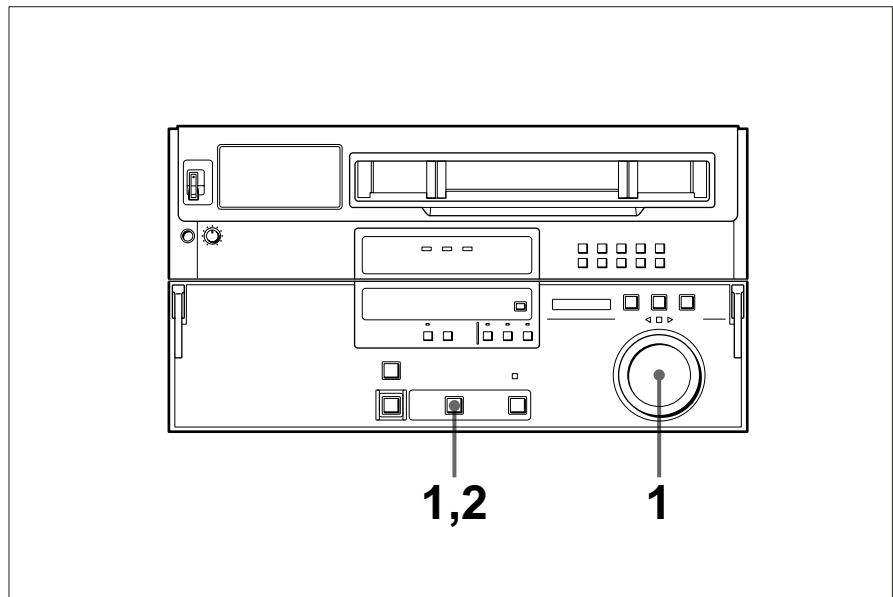

Capstan override playback

- 1** To adjust the playback speed, rotate the search dial while holding down the PLAY button.

The speed adjustment range is $\pm 15\%$ (in steps of 1%).

- 2** Release the PLAY button after completing the adjustment of the playback phase.

The VTR returns to normal-speed playback and the SERVO indicator lights.

5-1 Head Cleaning

Use the special BCT-5CLN Cleaning Cassette to clean the heads. Read the instructions included with the cleaning cassette carefully, as improper usage can damage the heads.

Follow the procedure below to clean the heads.

- 1** Insert the cleaning cassette.
- 2** Press the EJECT button simultaneously with the PLAY button.

Head cleaning starts.

After head cleaning continues for five seconds, the cleaning cassette is automatically ejected.

Note

Perform Step **2** immediately after inserting the cleaning cassette. If you do not, the cassette will be ejected after two or three seconds and no head cleaning will be done.

5-2 Moisture Condensation

If you suddenly move the VTR from a cold location to a warm one, or use the VTR in a very humid place, moisture in the air can form on the head-drum or tape guide. This is called moisture condensation. If you play a tape under these conditions, the tape may adhere to the drum where moisture has collected and become damaged.

If moisture condenses on the head-drum while you are operating the VTR, the AUTO OFF indicator lights and the error message “Error-10” appears in the time counter display.

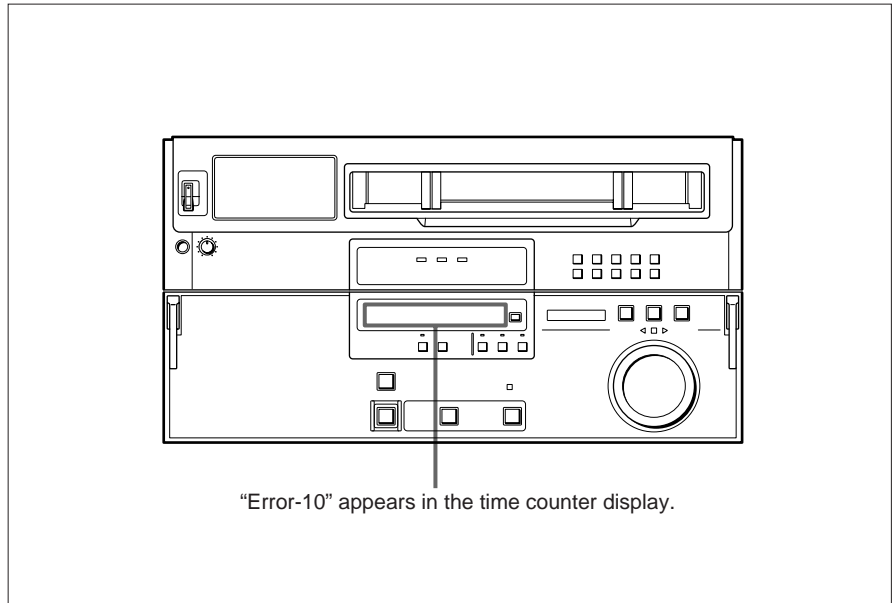

When moisture condensation has occurred

When this error message appears, the drum and capstan motors stop and the cassette is automatically ejected. The drum then starts to rotate again to dry the surface of drum.

Once the moisture has evaporated, the error message disappears.

If the AUTO OFF indicator lights and “Error-10” appears immediately after turning the VTR on

Leave the VTR turned on and wait until the indicator goes off. Inserting a cassette is not possible while this indicator is on.

When the indicator goes off and the error message disappears, you can use the VTR.

If you move the VTR from a cold to a warm location

Leave the VTR turned off for about ten minutes since some time is needed for the condensation-detection mechanism to work.

Specifications

General

Power requirements	100 to 240 VAC \pm 10%, 50/60 Hz
Power consumption	150 VA (240 V)
Peak inrush current	(1) Power ON, current probe method: 15A (100V), 30A (240V) (2) Hot switching inrush current, measured in accordance with European standard EN55103-1: 10A (230V)
Operating temperature	+5°C to +40°C (+41°F to +104°F)
Storage temperature	-20°C to +60°C (-4°F to +140°F)
Humidity	25% to 80% (relative humidity)
Mass	31 kg (68 lb 5 oz)
Dimensions	427 × 237 × 520 mm (16 ³ / ₄ × 9 ³ / ₈ × 20 ¹ / ₂ inches) (w/h/d)
Tape speed	96.7 mm/s
Playback time	124 minutes (using BCT-D124L) 40 minutes (using BCT-D40)
Fast forward/rewind time	Approx. 3 minutes using BCT-D124L
Search speed	Shuttle mode: Still to approx. \pm 50 times normal playback speed Variable mode: -1 to +3 times normal playback speed Jog mode: 0 to \pm 1 or \pm 3 times normal playback speed (selectable in set-up menu)
Dynamic tracking range	-1 to +3 times normal playback speed
Servo lock time	0.5 seconds or less (from standby on)
Load/unload time	6 seconds or less

Recommended tapes

Digital BETACAM cassette
BCT-D6/D12/D22/D32/D40/
D34L/D64L/D94L/D124L or
equivalent

Digital video format

Sampling frequency	Y: 13.5 MHz R-Y/B-Y: 6.75 MHz
Quantization	10 bits/sample
Compression	Coefficient recording system
Channel coding	S-NRZI PR-IV
Error correction	Reed-Solomon code
Error concealment	Adaptive three dimensional

Analog composite output

Bandwidth	Y: 0 to 5.0 MHz +0.5 dB/ -2.0 dB
S/N ratio	54 dB or more ¹⁾
Differential gain	3% or less
Differential phase	3° or less
Y/C delay	20 ns or less
K factor (2T Pulse)	1.5% or less

Digital audio format (CH-1 to CH-4)

Sampling frequency	48 kHz (synchronized with video)
Quantization	20 bits/sample
Wow and flutter	Below measurable level
Headroom	20 dB (factory setting), 18 dB or 16 dB, selectable
Emphasis	T1=50 μ s, T2=15 μ s

Analog output (CH-1 to CH-4)

D/A quantization	18 bits/sample
Frequency response	20 Hz to 20 kHz +0.5 dB/-1.0 dB (0 dB at 1 kHz)
Dynamic range	More than 85 dB (at 1 kHz, emphasis on)
Distortion	Less than 0.08% (at 1 kHz, emphasis on, reference level ²⁾)
Crosstalk	Less than -70 dB (at 1 kHz, between any two channels)

1) measured in video set-up 0% mode.

2) Reference level: +4 dBm

Specifications

Analog audio (Cue track)

Frequency response	100 Hz to 12 kHz ± 3 dB
S/N ratio	More than 45 dB (at 3% distortion level)
Distortion	Less than 2% (T.H.D at 1 kHz reference level ¹⁾)
Wow and flutter	DVW-522: Less than 0.2% rms DVW-522P: Less than 0.2% rms (DIN 45507 weighted)

Output connectors

COMPOSITE VIDEO OUTPUT

BNC (2 including 1 for character superimposition)
1 V_{p-p}, 75 Ω , sync negative
RF (with character superimposition)

MONITOR OUTPUT (L/R)

XLR, 3-pin, male (2)
+4 dBm at 600 Ω load, low impedance, balanced
RF: -10 dBu, at 10k Ω load, unbalanced (mixed L and R)

PHONES

JM-60 stereo phone jack
- to -12 dB at 8 Ω load, unbalanced

Optional accessories

BKDW-510	Control Panel Extension Kit
BKDW-511	Control Panel Case
RMM-110	Rack Mounting Kit
BCT-5CLN	Cleaning Cassette Tape
RFU-89EKA	RFU Adaptor Kit (for Europe)
RFU-89UCKA	RFU Adaptor Kit (for USA/Canada)
RFU-89ASKA	RFU Adaptor Kit (for Australia)

Design and specifications are subject to change without notice.

Remote connectors

CONTROL PANEL

D-sub 15-pin, female

RS232C

D-sub 25-pin, female

Accessories supplied

- AC power cord (1)
- PSW 4 \times 16 screws for rack mounting (4)
- Operation Manual (1)
- Maintenance Manual Part 1 (1)

1) Reference level: +4 dBm

A

AC IN connector 2-9
Advanced playback functions 1-3

B

BCT-5CLN 5-1, A-2
BKDW-510 1-5, A-2
BKDW-511 1-5, A-2
BREAKER button 2-9

C

Capstan override playback 1-3, 4-7, 4-8
CHARACTER switch 2-7, 2-8
COMPOSITE VIDEO OUTPUT connectors 2-9
Connecting external equipment 3-1
Connector panel 2-9, 2-10
Control panel 2-1
CONTROL PANEL connector 2-9, 2-10
CONTROL PANEL switch 2-7, 2-8
COUNTER buttons 2-5
Customized menu
 changing the setting of items 3-11
 to return to the factory setting values 3-13

D

DF/NDF switch 2-7
Digital hour meter 1-4, 3-4, 3-5
Displaying
 CTL counter data 4-2
 time codes 4-2
 user's bits 4-2

E

EJECT button 2-3
Ejecting a cassette 3-17

F, G, H

Features 1-2 to 1-4
Handling cassettes 3-16, 3-17
Head cleaning 5-1

I

Indicators 2-2
Inserting a cassette 3-16

J, K, L

JOG button 2-4
Jog mode playback 4-4
Locations and functions of parts and controls 2-1 to 2-10
Lower control panel
 search operation section 2-4
 tape transport section 2-3
 time code section 2-5, 2-6

M, N

Maintenance 5-1, 5-2
MENU button and indicator 2-5
Moisture condensation 5-2
MONITOR OUTPUT connectors 2-9, 2-10
MONITOR SELECT buttons 2-2
Normal-speed playback 4-3

O

Optional accessories 1-5, A-2
Outline of the DVW-522/522P 1-1

P

PHONES jack 2-2
PHONES level control 2-2
Playback 4-3 to 4-8
PLAY button 2-3
POWER switch 2-2
Preparing for playback
 selecting time data to be displayed 4-2
 setting switches 4-1

R

Reading hours meter information 3-5, 3-6
Recommended cassettes 3-16
References 1-5
Removing a cassette when tape slacking has occurred 3-17
RESET button 2-5, 2-6
RF ADAPTOR connectors 2-9
RFU-89EKA/UCCA/ASKA A-2
RMM-110 A-2
RS232C connector 2-9, 2-10

S

Search dial 2-4
SERVO indicator 2-3
SET button 2-5
SET UP SELECT switch 2-7, 2-8
Setting up the VTR 3-1 to 3-13
Set-up menu
 changing menu settings 3-7 to 3-10
 items related to the digital hours meter 3-4, 3-5
 items that require setting for operations 3-2 to 3-4
 item to be set only during tracking adjustments 3-6
 restoring factory-set values 3-10
SHUTTLE button 2-4
SHUTTLE/JOG indicators 2-4
Shuttle mode playback 4-5, 4-6
Specifications A-1, A-2
STANDBY button 2-3
STOP button 2-3
Superimposed characters 3-2, 3-3, 3-14, 3-15
System set-up panel 2-7, 2-8

T, U

Tape format 1-2
TC selector 2-7
Time counter display 2-5
Upper control panel 2-2

V, W, X, Y, Z

VAR button 2-4
Variable mode playback 4-6, 4-7
Variable-speed playback 4-4 to 4-7

このマニュアルに記載されている事柄の著作権は当社にあり、説明内容は機器購入者の使用を目的としています。

従って、当社の許可なしに無断で複写したり、説明内容（操作、保守等）と異なる目的で本マニュアルを使用することを禁止します。

The material contained in this manual consists of information that is the property of Sony Corporation and is intended solely for use by the purchasers of the equipment described in this manual.

Sony Corporation expressly prohibits the duplication of any portion of this manual or the use thereof for any purpose other than the operation or maintenance of the equipment described in this manual without the express written permission of Sony Corporation.

Le matériel contenu dans ce manuel consiste en informations qui sont la propriété de Sony Corporation et sont destinées exclusivement à l'usage des acquéreurs de l'équipement décrit dans ce manuel.

Sony Corporation interdit formellement la copie de quelque partie que ce soit de ce manuel ou son emploi pour tout autre but que des opérations ou entretiens de l'équipement à moins d'une permission écrite de Sony Corporation.

Das in dieser Anleitung enthaltene Material besteht aus Informationen, die Eigentum der Sony Corporation sind, und ausschließlich zum Gebrauch durch den Käufer der in dieser Anleitung beschriebenen Ausrüstung bestimmt sind.

Die Sony Corporation untersagt ausdrücklich die Vervielfältigung jeglicher Teile dieser Anleitung oder den Gebrauch derselben für irgendeinen anderen Zweck als die Bedienung oder Wartung der in dieser Anleitung beschriebenen Ausrüstung ohne ausdrückliche schriftliche Erlaubnis der Sony Corporation.

